

# QSC™

**A U D I O**

## *ISA Series Installed Sound Amplifiers*

User Manual

- ISA 300T
- ISA 500T
- ISA 800T
- ISA 280
- ISA 450
- ISA 750

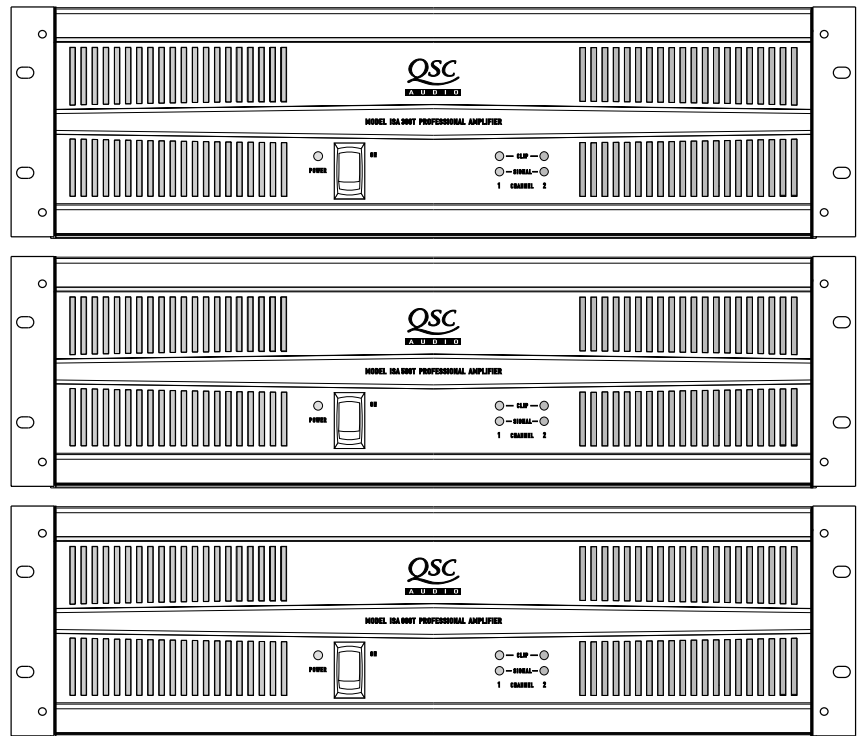

## ISA Audio Power Amplifiers



TD-000093-00 rev.C

# IMPORTANT SAFETY PRECAUTIONS & EXPLANATION OF SYMBOLS



## CAUTION

**RISK OF ELECTRIC SHOCK  
DO NOT OPEN**



CAUTION: TO REDUCE THE RISK OF ELECTRIC SHOCK, DO NOT REMOVE THE COVER. NO USER-SERVICEABLE PARTS INSIDE. REFER SERVICING TO QUALIFIED PERSONNEL.



The lightning flash with arrowhead symbol within an equilateral triangle is intended to alert the user to the presence of uninsulated "dangerous" voltage within the product's enclosure that may be of sufficient magnitude to constitute a risk of electric shock to humans.



The exclamation point within an equilateral triangle is intended to alert the user to the presence of important operating and maintenance (servicing) instructions in this manual.



The lightning flashes printed next to the OUTPUT terminals of all ISA amplifiers are intended to alert the user to the risk of hazardous energy. Output connectors that could pose a risk are marked with the lightning flash. **Do not touch output terminals while amplifier power is on. Make all connections with amplifier turned off.**



**WARNING: TO PREVENT FIRE OR ELECTRIC SHOCK, DO NOT EXPOSE THIS EQUIPMENT TO RAIN OR MOISTURE.**

This amplifier has a serial number located on the rear panel. Please write this and the model number down and keep them for your records.

Model: ISA \_\_\_\_\_

Serial Number: \_\_\_\_\_

Date of Purchase: \_\_\_\_\_

Purchased From: \_\_\_\_\_

## FCC INTERFERENCE STATEMENT

NOTE: This equipment has been tested and found to comply with the limits for a class B digital device, pursuant to part 15 of the FCC rules. These limits are designed to provide reasonable protection against harmful interference in a residential installation. This equipment generates, uses, and can radiate radio frequency energy and if not installed and used in accordance to the instructions, may cause harmful interference to radio communications. However, there is no guarantee that interference will not occur in a particular installation. If this equipment does cause harmful interference to radio or television reception, which can be determined by switching the equipment off and on, the user is encouraged to try to correct the interference by one or more of the following measures:

- Reorient or relocate the receiving antenna.
- Increase the separation between the equipment and the receiver.
- Connect the equipment into an outlet on a circuit different from that to which the receiver is connected.
- Consult the dealer or an experienced radio or TV technician for help.

© Copyright 2000, QSC Audio Products, Inc.

QSC® is a registered trademark of QSC Audio Products, Inc.

"QSC" and the QSC logo are registered with the U.S. Patent and Trademark Office

The Audio Precision logo is the property of Audio Precision, Beaverton OR

All trademarks are the property of their respective owners.

# TABLE OF CONTENTS

---

|  |    |
|--|----|
| <b>INTRODUCTION:</b>   |    |
| ISA Series Overview .....  | 4  |
| Front Panel Illustration .....   | 4  |
| Rear Panel Illustrations .....   | 5  |
| <b>FEATURES &amp; SETUP :</b>  |    |
| Power Switch .....   | 6  |
| Cooling Air Inlet and Exhaust Vents .....                                    | 6  |
| LED Indicators .....   | 7  |
| Gain Controls .....  | 8  |
| Input Jacks .....  | 8  |
| DataPort V2 Connector .....  | 9  |
| Daisy Chaining to Other Devices from the DataPort V2 .....                   | 9  |
| Stereo & Parallel Operating Modes .....                                      | 10 |
| DIP Switch Settings .....  | 11 |
| Bridge Mono Operating Mode .....   | 12 |
| DIP Switch Settings .....  | 12 |
| Low Frequency Filter .....   | 13 |
| DIP Switch Settings .....  | 13 |
| Frequency Response Curves .....  | 14 |
| Clip Limiter .....   | 15 |
| DIP Switch Settings .....  | 15 |
| <b>INSTALLATION:</b>   |    |
| Rack Mounting .....  | 16 |
| Mounting Dimensions .....  | 16 |
| Cooling Requirements .....   | 17 |
| AC Mains (AC Power) .....  | 17 |
| <b>CONNECTIONS:</b>  |    |
| Inputs: XLR and Terminal Block Input Jacks .....                             | 18 |
| Inputs: DataPort V2 Connections and Notes .....                              | 19 |
| Outputs: Using the Screw Terminal Connections .....                          | 20 |
| Outputs: Direct Low Impedance (2-16 ohm loads) .....                         | 21 |
| Outputs: Distributed High Impedance ("T" models only) .....                  | 22 |
| Power Sharing Between High and Low Impedance Outputs ("T" models only) ..... | 24 |
| Securing Output Wiring to the Chassis .....                                  | 25 |
| <b>OPERATION:</b>  |    |
| Gain Controls .....  | 26 |
| AC Power Switch .....  | 26 |
| Front Panel LED Indicators .....   | 26 |
| Normal Operating Levels .....  | 26 |
| <b>APPLICATIONS:</b>   |    |
| General Notes, Distributed Line Principles .....                             | 27 |
| Low Frequency Filtering, Distributed Output Examples .....                   | 28 |
| Multiple Low Impedance Loads in Series or Parallel Connections .....         | 30 |
| DataPort V2 Application Information .....                                    | 32 |
| <b>TROUBLESHOOTING</b> .....   | 33 |
| <b>SPECIFICATIONS</b> .....  | 35 |
| <b>WARRANTY INFORMATION</b> .....  | 39 |
| <b>HOW TO CONTACT QSC AUDIO PRODUCTS</b> .....                               | 39 |

# INTRODUCTION- INTRODUCTION AND FRONT PANEL ILLUSTRATION

Thank you for the purchase of your new ISA amplifier. To get the most out of your amplifier, review this manual carefully. The installation, connection and operation sections provide useful guidelines to get you up and running quickly and correctly.

## The QSC shipping box should contain:

- 1- The amplifier
- 2- This user manual
- 3- #14AWG AC line cord with IEC connector

After you have removed the amplifier from the box, make sure you save the box and packing material for safely storing or shipping the amplifier in the future.

The ISA Series amplifiers offer professional-quality performance at an affordable price. Three power-points are offered in both directly-coupled and autotransformer-coupled output. Output power at 2 ohms ranges from 430 to 1200 watts per channel.

The ISA amplifier was designed to fit your installed sound requirements. The detented gain controls, located on the rear panel, provide accurate, repeatable adjustments. Each channel has defeatable clip limiting and selectable-response low frequency filters. QSC's rear-to-front airflow cooling helps to keep other system components in the equipment rack cooler, enhancing overall system reliability.

For those systems with QSC DataPort accessories (DSP, crossovers & filters, remote cinema monitoring) a DataPort V2 (version 2) is included on all ISA models. Consult your QSC representative for accessory compatibility information.

The ISA amplifiers are easy to use. All operating mode switches are grouped together on the rear panel. A mode switch configuration chart is printed directly on the rear panel for easy, accurate reference. This helps to avoid configuration problems. On the autotransformer-coupled "T" models, separate screw-terminal output connections are provided for both low impedance loads and high impedance (25/70/100 volt) loads. The "connectability" of the "T" models makes them simple to use in almost any installed sound application.

The ISA amplifiers are built for long service life. XLR and terminal block input connectors provide tight, noise-free connections. The chassis design incorporates robust output cable dressing tie-down points to keep stress off the connections, making them more reliable. All signal processing is done in side loops and then returned to the main signal path. This maintains high signal fidelity and provides a more robust system.

Your new ISA amplifier will give you many years of great sound. It is the best value in installed sound amplification with legendary QSC durability and performance.

## FRONT PANEL

(all models)

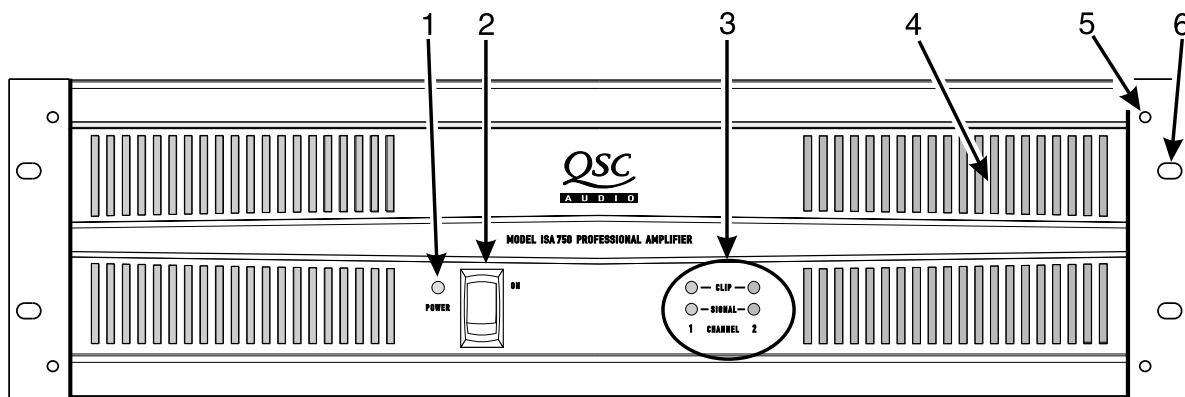

1. Power indicator LED
2. Power switch
3. Clip and Signal indicator LEDs

4. Cooling air exhaust vents
5. Mounting holes for optional handles
6. Mounting holes for rack mounting

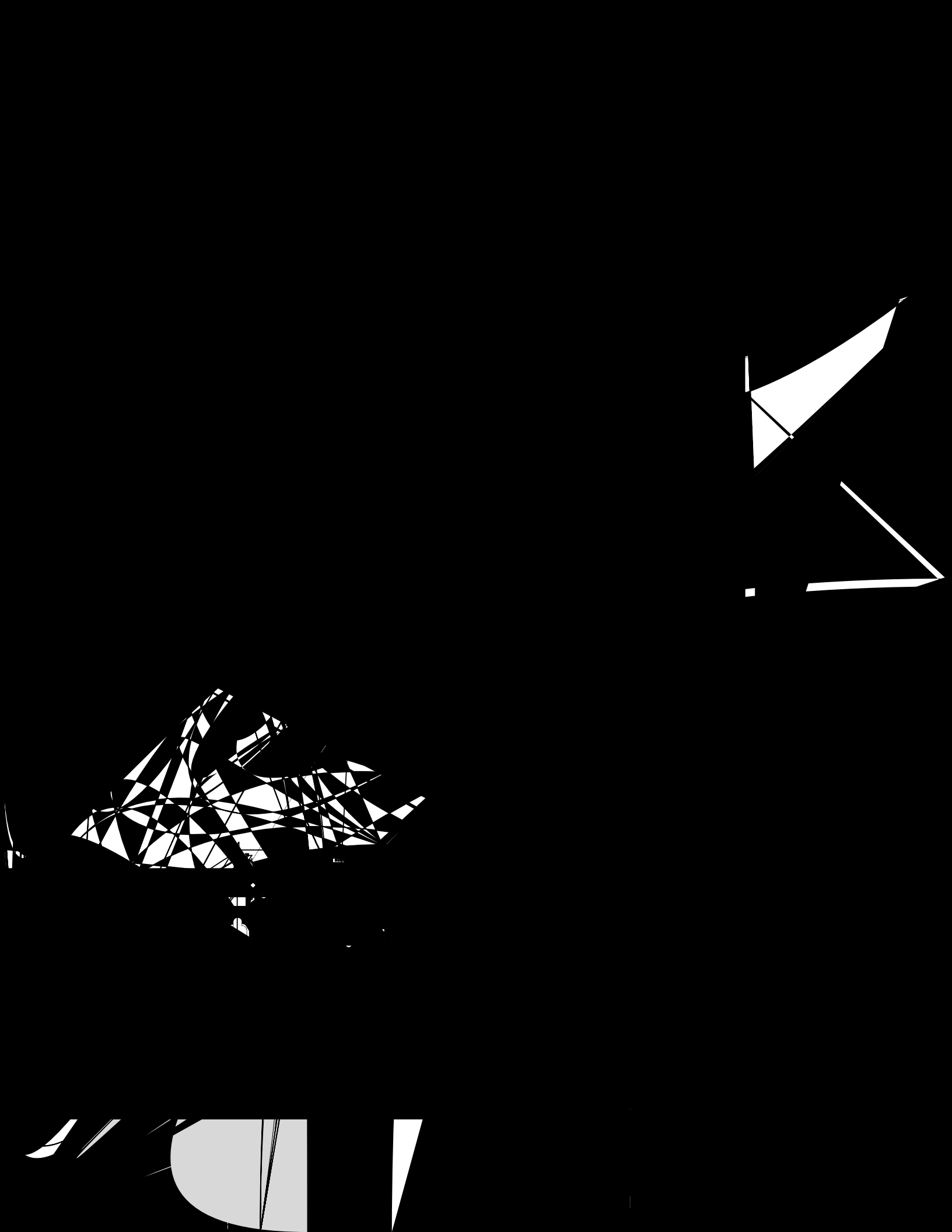

# FEATURES & SETUP- POWER SWITCH, COOLING AIR VENTS

The front panel of ISA series amplifiers is tailored for installed sound. The power switch is the only front panel control; gain controls are located on the rear panel to minimize control tampering. LED indicators are provided for power, input signal and to warn of clipping.

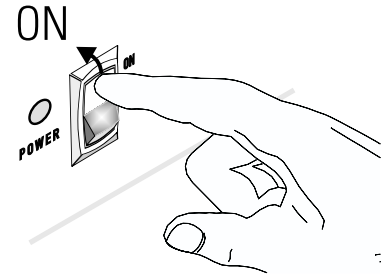

The power switch is a rocker-type switch. To turn the amplifier on, push in on the top portion of the switch. To turn the amplifier off, push in on the bottom portion of the switch.

The green power LED should light up when the switch is in the on position.

When the power is switched off, the LED may take several seconds to go out; this is normal.

### If the POWER LED fails to illuminate when the switch is in the ON position:

- 1- Check the AC cord and insure that both ends are fully inserted into their receptacles. If the power LED still fails to illuminate,
- 2- Check the AC outlet for voltage with a circuit tester or known good device (lamp, etc.).
- 3- Check the AC circuit breaker on the rear panel of the amplifier. The illustration at the right shows the circuit breaker in its normal (operating) position and its tripped position (amplifier AC power turned off by protective circuit breaker).



**If the circuit breaker opens repeatedly with nothing connected to the amplifier and it is connected to the proper AC source as labeled on the rear panel serial number label, then the amplifier requires servicing.**

**Rear panel circuit breaker:**  
Normal operating position

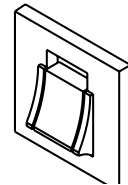

**Rear panel circuit breaker:**  
Tripped or open position;  
press to reset.

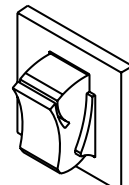

Keep the inlet and exhaust air vents clear of any obstructions. Insure that the air exhausted from the vents has an exit from the equipment enclosure.

Equipment enclosures with insufficient air flow will cause amplifier overheating. Enclosures must allow fresh air to enter and hot air to exit.

If dust builds up, clogging the vents, use a soft brush and a vacuum cleaner to remove the dust. Use the brush to loosen the dust while the vacuum is used to pull the dust away from the amplifier.

## FEATURES & SETUP- LED INDICATORS

---



**POWER:** green LED that illuminates when the power switch is set to the on position and AC power is present at the IEC cord receptacle.

**Normal indication:** at power-on the LED will illuminate at half-brightness for 2-3 seconds, then it illuminates to full-brightness.

**If no indication:** see previous page for suggested items to check.

**When power is switched off:** the LED may take several seconds to extinguish (go out); this is normal.

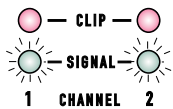

**SIGNAL:** green LED that lights up when the input signal is strong enough to drive the output to about -40 dB from rated 8-ohm power.

**Normal indication:** varying brightness corresponding to strength of input signal.

**If no indication:** check gain settings, input cables, connections and audio source. If audio source is extremely low signal strength, signal LED may not illuminate; this is normal but indicates that the input signal strength should be increased.

**Occasional illumination:** normal for weak input signal strength.

**Illuminated dimly all the time with brighter flashing:** normal for "average" input signal strength.

**Fully illuminated (on):** normal for "pushing" the amplifier hard. Also, the clip indicator will probably flash dimly with the beat of the program material and brightly during extreme peaks in the material.

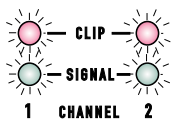

**CLIP:** red LED that illuminates when the amplifier clips.

**Normal indication:** illumination briefly at extreme output power peaks. Occasional clipping (once briefly every few seconds) when operation at high power levels is normal. At power-on, the clip LEDs may briefly flash; this is normal.



Continuous operation at high power may trigger the thermal protection circuitry, shutting down the amplifier and fully illuminating the clip LED. Operation will resume after the amplifier has cooled down sufficiently.

**If no indication:** normal if the amplifier is operated at very low output levels.

**Occasional illumination:** Occasional clipping (once briefly every few seconds) when operation at high power levels is normal. Continuous operation at high power may trigger the thermal protection circuitry, shutting down the amplifier and fully illuminating the clip LED.

**Illuminated most of the time:** Not normal; reduce the output of the amplifier and/or input signal to avoid thermal shutdown of the amplifier and possible speaker damage.

**Fully illuminated (on):** Amplifier is in thermal shut down. Reduce gain settings or input signal and allow the amp to cool down. Leave the power on so that the fan continues to run; operation will automatically resume after the amplifier has cooled sufficiently.

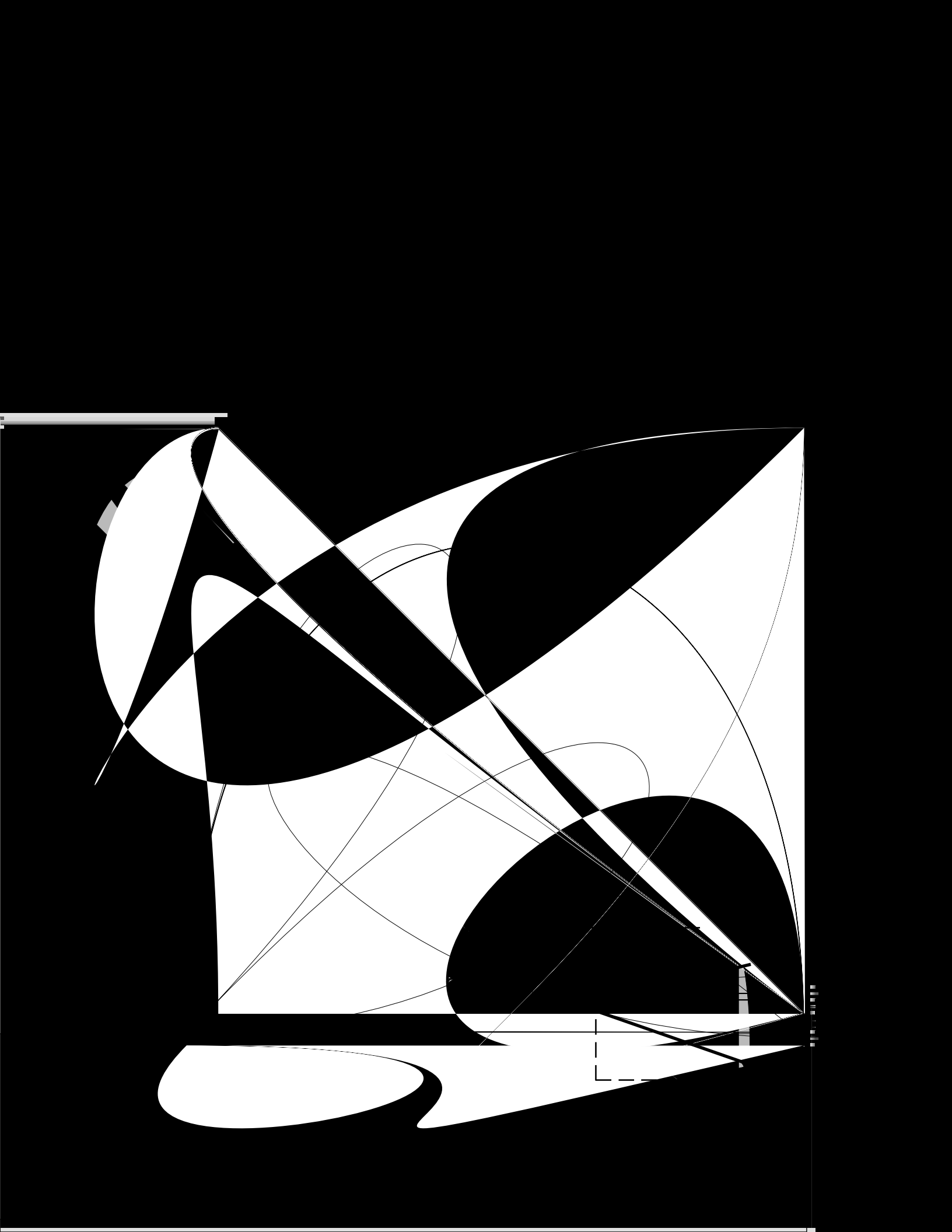



# FEATURES

## DATAPORT

**What It Is-** The QSC DataPort provides remote control functions.

The "V2" DataPort maintains essential supply +15 VDC

## What Can I

Consult your

Using Module  
Filter  
& Monitors  
(additional information)

**NOTE:** The DataPort V2 can only supply a maximum current of 40 mA. Some accessories such as the DSP-3 require more than 40 mA to operate. Use an external power source for such accessories.

## Daisy Chaining to Other Amplifiers While Using the DataPort

signal. The basic daisy chain setup. Note that the XLR connector may also be used for daisy chaining. Other daisy chain accessories may not be used. Daisy chaining is not recommended for accessories using terminal block connections.

## Using the DataPort V2-

QSC DataPort Cable carries audio inputs

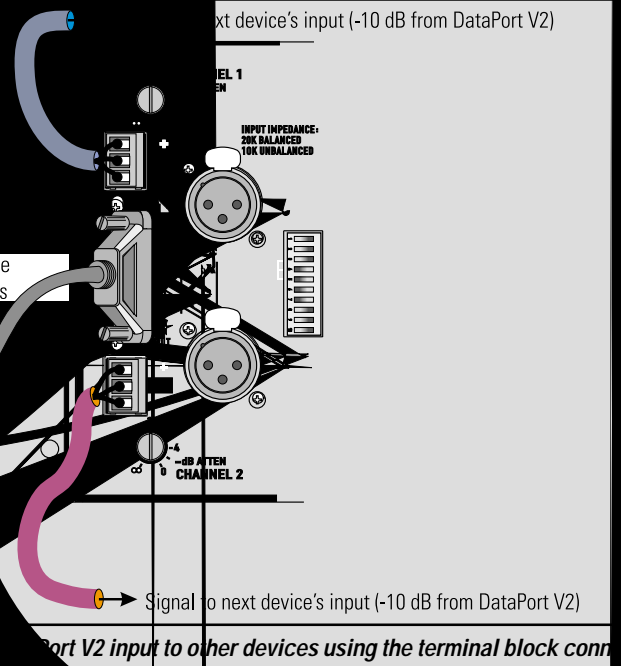

Port V2 input to other devices using the terminal block conn

# FEATURES & SETUP- STEREO & PARALLEL OPERATING MODES

## STEREO:

Each input signal is sent to its respective channel. Each channel has independent low-frequency (subaudio) filtering, clip limiting, gain control, and output connection.

**When to use STEREO input configuration:** Use stereo mode for stereo sources (L-R inputs) and any other situation that requires each channel to be completely separate from the other.

### How to use STEREO mode:

- 1- Set the DIP switches for stereo mode operation (see facing page).
- 2- Connect the two input signals; one to CH1 and one to CH2 (XLR or terminal blocks)
- 3- Connect the two speakers; one to CH1's output terminals, one to CH2's output terminals.

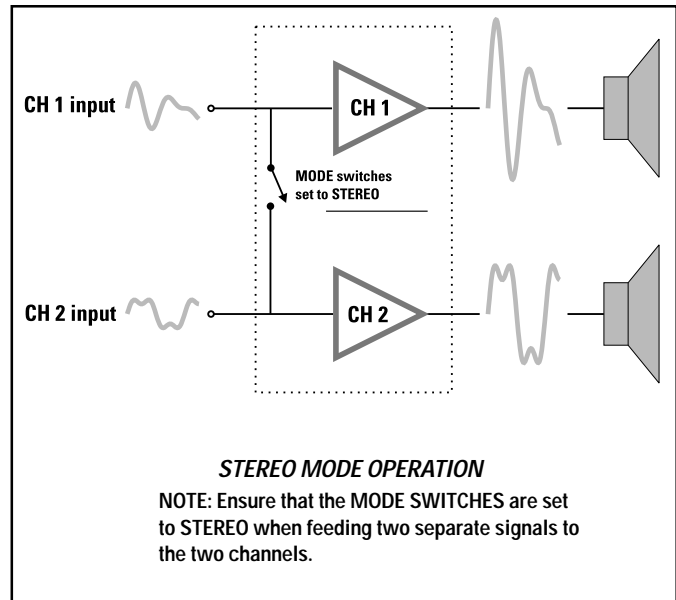

## PARALLEL:

The channel 1 and channel 2 inputs are connected together, applying a *single input signal* to both channels of the amplifier. A signal into any input jack will drive both channels. Each channel's low frequency filtering, clip limiting, and gain control still function independently. Each channel drives its own speaker load.

You can patch the input signal on to additional amplifiers (daisy chain) by using any of the remaining input jacks. This feature eliminates the need for "Y" cables.

**When to use PARALLEL input configuration:** Use parallel mode when you need one signal to drive both channels; each channel having its own control (gain, clip limiter, low-frequency filter).

### How to use PARALLEL mode:

- 1- Set the DIP switches for PARALLEL mode (see facing page).
- 2- Connect the one input signal to any one input connector.
- 3- Connect the two speakers: one to CH1's output terminals, one to CH2's output terminals.

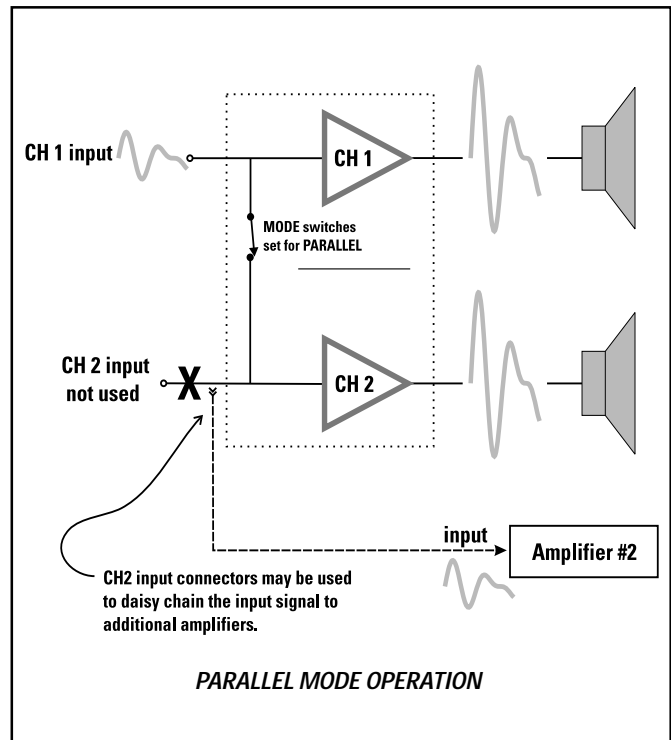

# FEATURES & SETUP- STEREO & PARALLEL MODE DIP SWITCH SETTINGS

## SETTING THE DIP SWITCHES FOR STEREO OR PARALLEL MODE- "non-T" models

### ISA 280, ISA 450, ISA 750:

Refer to the switch setting keys for each mode, to the right.

These keys are printed on the amplifier's rear panel for easy reference when you are behind the equipment rack.

**STEREO Mode-** Set switch #4, 5, 6 and #7 to the left.

**PARALLEL Mode-** Set switch #4 and #5 to the right; set switch #6 and #7 to the left.

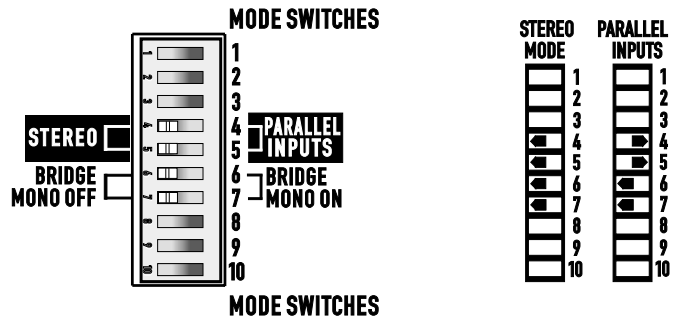

ISA 280, ISA 450 and ISA 750 mode switches.

## SETTING THE DIP SWITCHES FOR STEREO OR PARALLEL MODE- "T" models

### ISA 300T, ISA 500T and ISA 800T:

Refer to the switch setting keys for each mode, at the right.

These keys are printed on the amplifier's rear panel for easy reference when you are behind the equipment rack.

**STEREO Mode-** Set switch #3, 4, 5, 6, 7 and #8 to the left.

**PARALLEL Mode-** Set switch #3, 4 and #5 to the right. Set switch #6, 7 and #8 to the left.

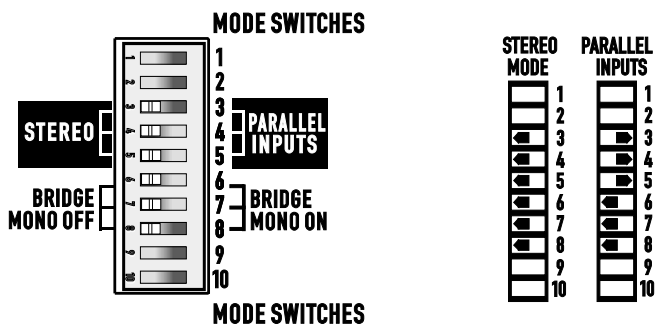

ISA 300T, ISA 500T and ISA 800T mode switches.

# BRIDGE MODE & SETUP- BRIDGE OPERATING MODE & DIP SWITCH SETTINGS

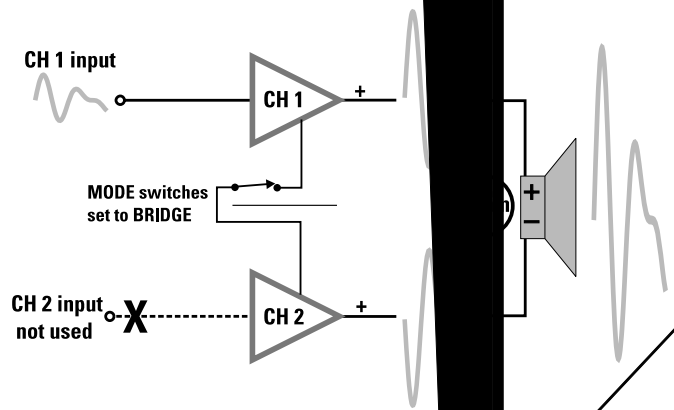

## BRIDGE MODE OPERATION-

Note that speaker connection for bridge mono mode is different than other modes. See section on Connections: Outputs for proper bridge mode output connections.

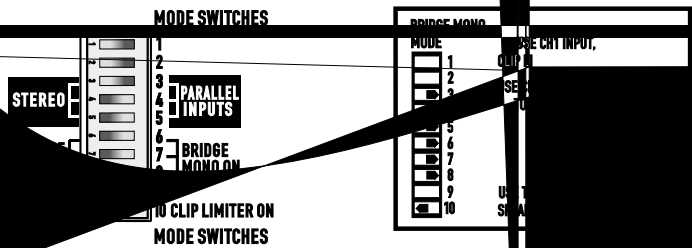

# FEATURES & SETUP- LOW FREQUENCY FILTER & DIP SWITCH SETTINGS

Generally, match the frequency selection to your speaker's low frequency capability. This improves speaker performance by limiting subaudio cone movement, making more power available for the speaker's rated frequency range. *Unless you already have filtering in the signal path preceding the amplifier, use the low frequency filter to protect your speakers from cone over-excursion caused by frequencies below the speaker's limits. The speaker's documentation will specify the low frequency limit.*

## Differences Between "T" & "non-T" Models:

**ISA 280, ISA 450 and ISA 750's** have defeatable low frequency filters with selectable roll-off frequencies of **30 and 70 hertz**. Each channel has its own low frequency filter which can be enabled or defeated using the filter on-off switch. The frequency is determined by the frequency selection DIP switch. There is a 5 hertz roll-off in the filter off position to protect the speaker loads from sub-audio or DC signals. The off position should be used only for subwoofer systems with rated frequency response below 30 hertz or if low frequency filtering is provided by other devices.

**ISA 300T, ISA 500T and ISA 800T's** have selectable roll-off frequencies of **50 and 75 hertz**. The frequency is determined by the frequency selection DIP switch. **The low frequency filter is always active and is not defeatable.** This is required by the presence of magnetic devices (coupling transformers) in constant voltage distributed audio systems. The low impedance outputs of these models have the same low frequency roll-off as the autotransformer coupled high impedance outputs.

## SETTING THE FILTER DIP SWITCHES-

- 1- Set switch #3 and #8 to the on or off position as desired.
- 2- Select the desired roll-off frequency at switch #2 and #9.
- 3- If filter off is selected, the frequency selection has no effect.

### ***If operating in BRIDGE MODE-***

- 1- When in bridge mode, channel 2's low frequency filter and clip limiter should be switched off.
- 2- Channel 1's filter settings (and clip limiter) determine amplifier behavior. Set channel 1's low frequency filter on-off switch, frequency selection switch and clip limiter as desired.

## **ISA 300T, ISA 500T and ISA 800T:**

### ***If operating in STEREO or PARALLEL MODE-***

- 1- Select the desired roll-off frequency (50 or 75 hertz) at switch #2 and #9. Each channel can be set independently.

### ***If operating in BRIDGE MODE-***

- 1- Select the desired roll-off frequency at switch #2. Setting of switch #9 is ignored.

### ***To Prevent Output Transformer Saturation-***

The 50 Hz filter setting prevents transformer saturation for normal, unclipped program levels. If heavy clipping is possible, use the 75 Hz setting for extra protection. See "Low Frequency Filtering for 70-100V Systems", page 28.

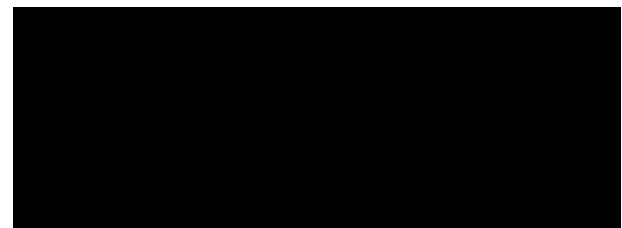

**ISA 280, ISA 450 and ISA 750 models: frequency selection is 30 and 70 hertz. Low frequency filter can be switched on or off with switches #3 and #8.**

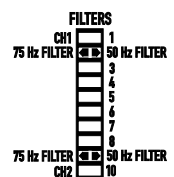
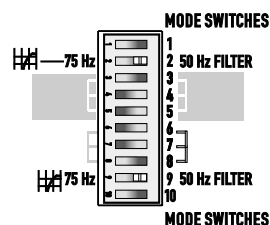

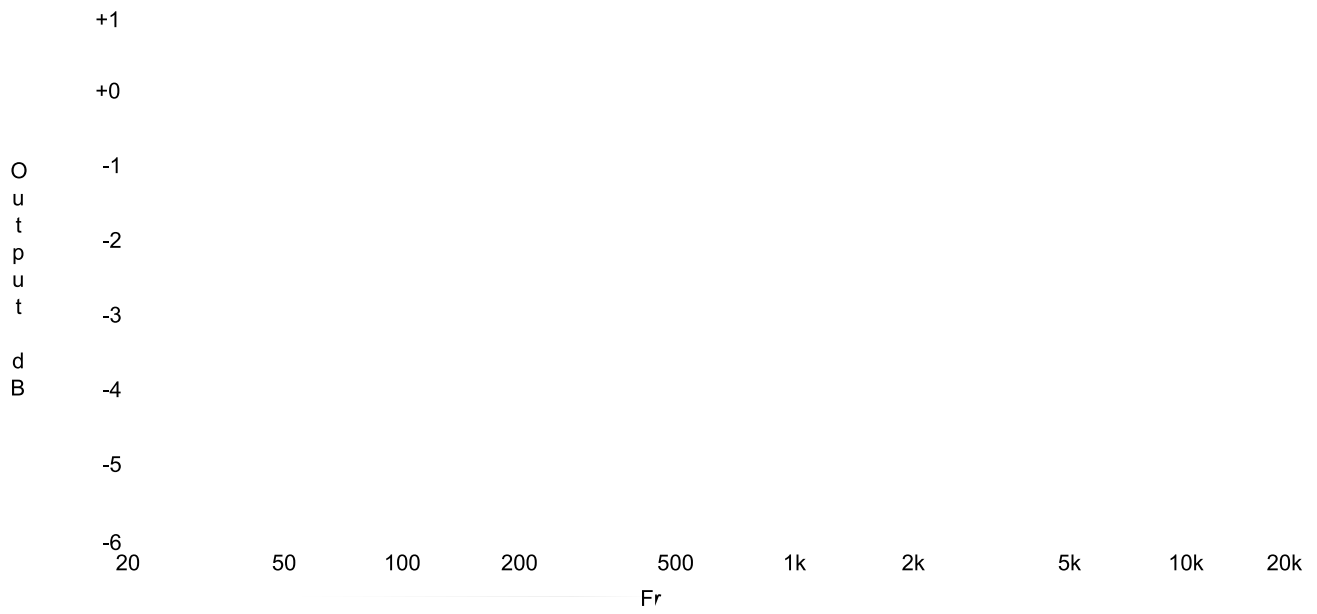
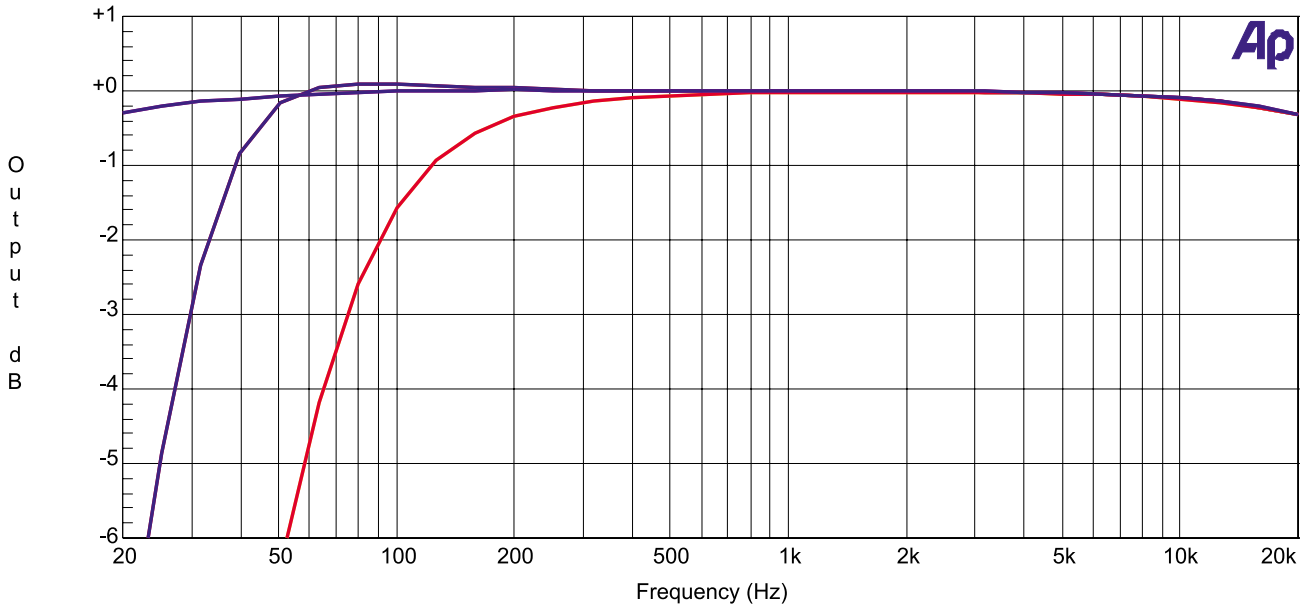

# FEATURES & SETUP- CLIP LIMITER & DIP SWITCH SETTINGS

---

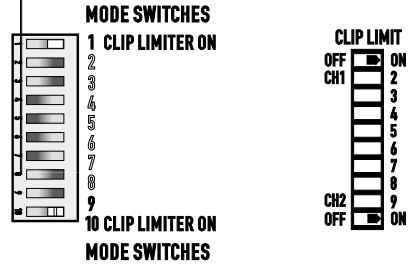

**CAUTION:** *Clip limiting reduces extreme overdrive peaks, allowing a higher average signal level without audible distortion. However, increasing the gain with the clip limiter engaged, until clipping is again audible, can double the average output power. Be careful not to exceed the power rating of your speakers.*

# INSTALLATION: RACK MOUNTING AND MOUNTING DIMENSIONS

**NOTE: Rack mounting of amplifier is optional.**

## Securing the Front Ears to the Rack Rails

Use four screws and washers when mounting the ISA amplifier to the front rails. Support the weight of the amplifier while securing it to the rails to avoid bending or distorting the front rack mount ears.



**Amplifiers are inherently heavy. It is highly recommended that you have an assistant support the amplifier during rack installation to avoid injury.**

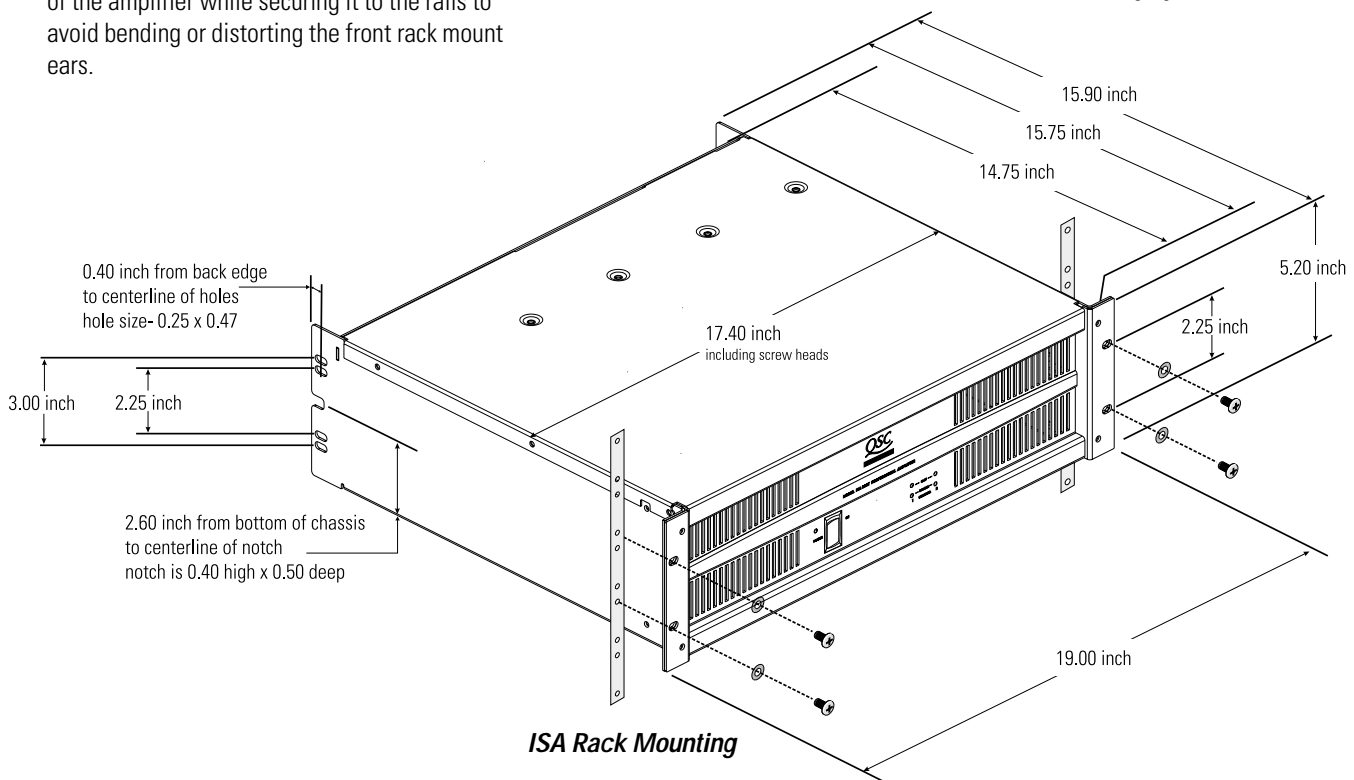

## Supporting the Rear of the Amplifier

Supporting the amplifier at the rear is extremely important, especially for mobile and portable use. Equipment is often installed in racks at a remote location, then later transported to the installation site. During transport, the shock loads encountered on the chassis and rack can easily damage an unsupported amplifier and the rack rails. Unless the amplifier is being installed in its final, fixed location, we strongly recommend supporting the rear of the amplifier.

Rear rack mounting ear kits are an accessory item and are available from QSC's Technical Services Department or from your dealer or distributor.

The rear rack mounting ear kit may be installed in two different ways. Refer to the literature included with the rack mounting ear kit for up-to-date information. The basic information is supplied here to give you an idea of how the accessory rack mounting ears are used.

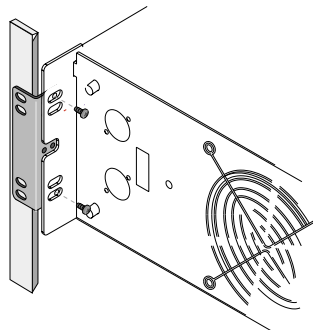

**Method 1-** The amplifier is first installed from the front of the rack and then the ears are secured directly to the amplifier with two machine screws as shown, left. Then the ears are secured to the rails using ordinary rail hardware.

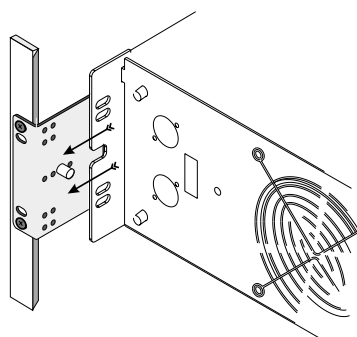

**Method 2-** The amplifier is first installed from the front of the rack. Then, the accessory rear ears are positioned on the rear rack rails and secured. The pin installation position can now be selected. Install the pin so that it fits well into the slot provided on the amplifier's rear mounting tab.



# INSTALLATION: COOLING REQUIREMENTS & AC MAINS

## FAN COOLING-

All QSC amplifiers draw cool air into the rear of the amplifier and exhaust the hot air from the front. This is done so that the equipment in the rack stays as cool as possible. This method of cooling also gives the technician “direct” air temperature feedback at the front of the rack, where it is the most convenient. The front panel’s temperature is an accurate indicator of “how hard” the amplifier is working.

The fan varies speed automatically to maintain safe internal temperatures and minimize noise. Keep the front and rear vents clear to allow full air flow.

Hot air exhausts out the front of the amp so it does not heat the interior of the rack. Make sure that plenty of cool air can enter the rear of the rack, especially if there are other units which exhaust hot air into it. Also ensure that the exhaust air from the front of the amplifier is not obstructed by an equipment cabinet door (or otherwise).

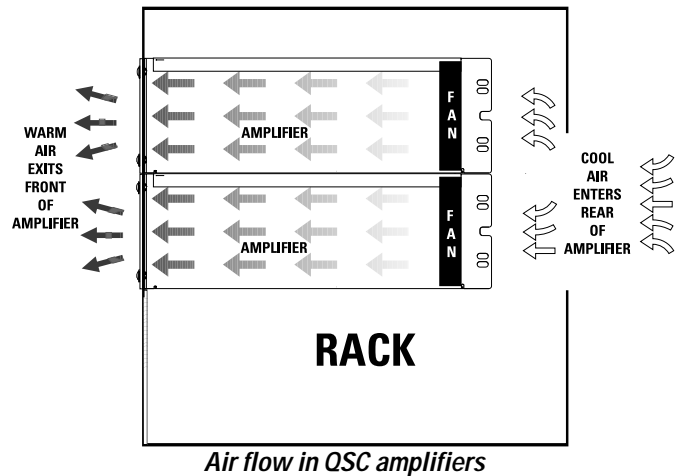

*Keep the front and rear vents clear to allow full air flow. Make sure that plenty of cool air can enter the rack, especially if there are other units which exhaust hot air into it.*

## OPERATING VOLTAGE (AC mains)-

**Connect the AC line cord** after the amplifier has been installed in the equipment rack. The IEC plug (the rectangular “block” plug-end of the AC power cord) can only be inserted when it is properly oriented with the IEC receptacle on the rear panel of the amplifier. Orient the IEC plug correctly and push the plug firmly into the IEC receptacle; it should seat tightly.

**The correct AC line voltage** is shown on the serial number label. Connecting to the wrong line voltage is dangerous and may damage the amplifier.

**The AC line cord** attaches to the IEC connector on the rear panel. Use the cord supplied with the amplifier, or an equivalent. Insure that the wire gauge of the cord is **#14AWG**. Use of #16 or #18 AWG can be dangerous and is not recommended. The larger AWG number indicates a physically smaller wire; smaller AWG number indicates a physically larger wire (#12 AWG is able to carry more current than #14AWG).

**Use the best possible connection to the AC power source.** Avoid extension cords as they will cause some voltage drop between the AC source and you amplifier. If the use of an extension cord is required, ensure that it is the shortest length possible and is at least #14 AWG. Smaller AWG number means larger wire size (example: #12 AWG is a larger physical wire size than #14 and able to carry more current). Ensure that all grounding connections are maintained.



*The correct AC line voltage is shown on the serial number label.*



*Connecting to the wrong line voltage is dangerous and may damage the amplifier or constitute the risk of electric shock. Verify the correct AC line voltage by checking the specification printed on the serial number sticker on the rear panel.*

# CONNECTIONS: INPUTS- XLR & TERMINAL BLOCK

Each channel has active balanced "Euro-style" terminal block and XLR input jacks wired in parallel. The input impedance is 20k ohm balanced or 10 k ohm unbalanced. Unused input jacks may be daisy chained to additional amplifiers.

Balanced connection is recommended. Balanced signals are less prone to AC hum and other electrical noise. Unbalanced signals can be suitable for short cable runs. The signal source's output impedance should be less than 600 Ohms to avoid high frequency loss in long cables.

If the DataPort V2 is being used for the input signal source, the XLR and terminal block connections should not be used for inputs. However, they may be used for daisy chaining the DataPort V2 input signal to other amplifiers. The signal available from the XLR and terminal block connections will be about 10 dB lower than the DataPort V2 signal.

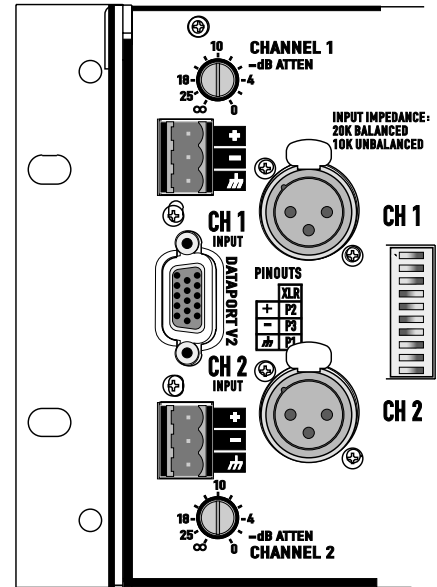

## Terminal Block Connectors:

## XLR Connectors:

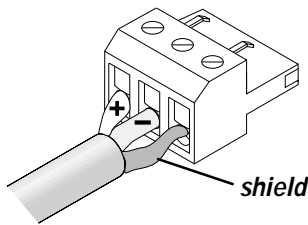

**Terminal block: balanced connections**

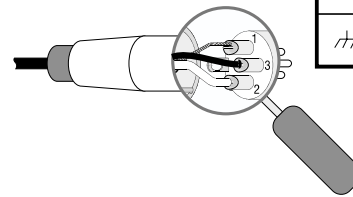

**XLR : balanced connection**

| XLR input pinout (balanced) |       |
|-----------------------------|-------|
| +                           | pin 2 |
| -                           | pin 3 |
| ⏏                           | pin 1 |

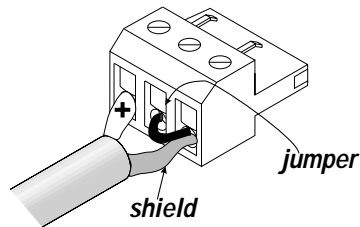

**Terminal block: unbalanced connections**

**Unbalanced inputs:** Connect the conductors to the connector as shown. Make sure that the unused side of the balanced input is connected to ground, as shown.

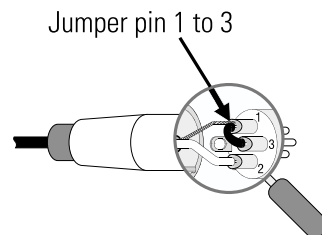

**XLR: unbalanced connection**

| XLR input pinout (unbalanced) |       |
|-------------------------------|-------|
| +                             | pin 2 |
| jumper pin1 to pin 3          |       |
| ⏏                             | pin 1 |

## CONNECTIONS: INPUTS- DATAPORT V2

---

The ISA series of amplifiers come with a DataPort V2 connector that may be used for connecting to accessory QSC DataPort devices. The V2 (or version 2) DataPort does not have the full capability of the standard DataPort. The DataPort V2 must be connected to a QSC DataPort product with a QSC DataPort cable; similar looking computer data cables will not work and could damage your QSC equipment. The DataPort V2 connection will supply the input signals to the amplifier. If using the DataPort V2 connection, do not apply inputs to the XLR or terminal block connectors.

If the ISA amplifier is being used in a system monitored through a QSC cinema monitor (or other QSC DataPort product) the following amplifier information will be provided by the amplifier DataPort V2:

CH1 and CH2 output voltage  
Amplifier AC power status (on or off)

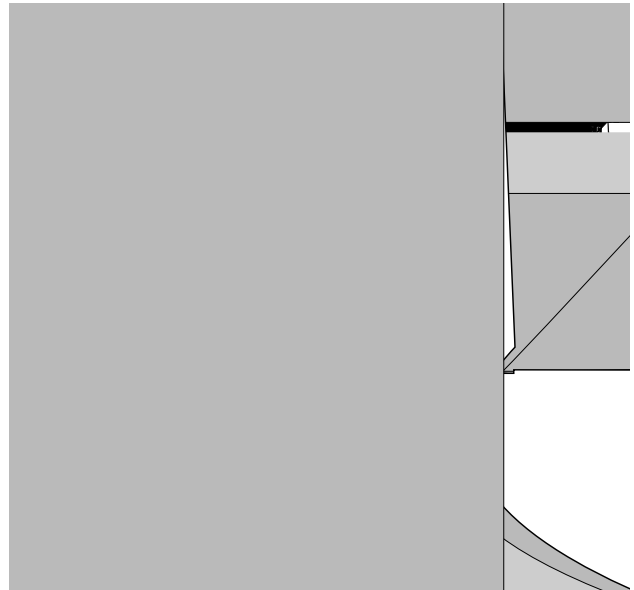

### **How to Connect to the DataPort V2:**

**If it is an accessory that mounts directly** to the rear of the amplifier, orient the accessory correctly and attach to the amplifier per the accessory's instructions.

**If the accessory attaches with a QSC DataPort cable**, orient the HD-15 male plug correctly with the DataPort V2 socket on the amplifier (it is "D" shaped and will fit only one way). Push the plug onto the socket firmly and ensure it is seated properly. Finger-tighten the 2 retaining screws. Do not over-tighten.

### **Basic Operation Notes:**

- 1- The amplifier Gain controls will need to be set at their anticipated high-level setting. Use reduced level setting during setup & test.
- 2- Control of the audio level will be accomplished with the DataPort accessory device to which the amp is connected.
- 3- No control of the amplifier's AC power will be possible via the DataPort V2. Use the amplifier's POWER switch to turn the amp on and off.
- 4- See page 32 for additional DataPort V2 Application information.



***If using the DataPort V2 connection, do not connect any inputs to the XLR or terminal block connectors. The unused XLR or terminal block inputs may be used for daisy chaining the DataPort V2 input signal to other amplifiers. The signal level available from the unused inputs will be about 10 dB lower than the signal applied at the DataPort V2 connector.***

# CONNECTIONS: OUTPUTS- USING THE SCREW TERMINAL CONNECTIONS

## GENERAL-

The screw terminal output connections are protected by a hinged plastic cover.

To make connections to the screw terminals, you will need to swing the cover door open. Gently pry the cover with your finger tips on the side that has the wire openings.

After the door is open, loosen the screws for the terminals you are planning to use. Do this by rotating the screw counter-clockwise with an appropriate screwdriver.

After loosening the screws, slide the tongue terminals under the head of the screw and seat the terminal firmly against the screw. Tighten the screw by rotating it clockwise with an appropriate screwdriver.

Alternately, wire connections may be made. Ensure that all wires are neatly terminated with no loose strands. Do not strip the insulation back excessively. Loose strands and exposed wire beyond the terminals may cause a short circuit and cause protective muting of the amplifier.

Once all connections have been made, close the protective cover by swinging it over the connections and pressing it toward the amplifier. If your wiring job is messy, you may need to loosen and reposition some cables to get a good fit for the cover.

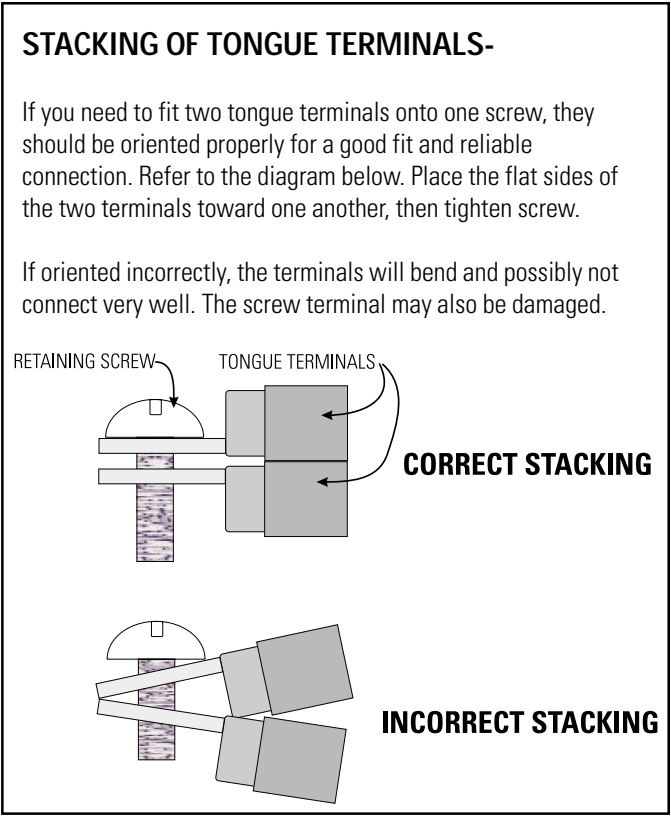
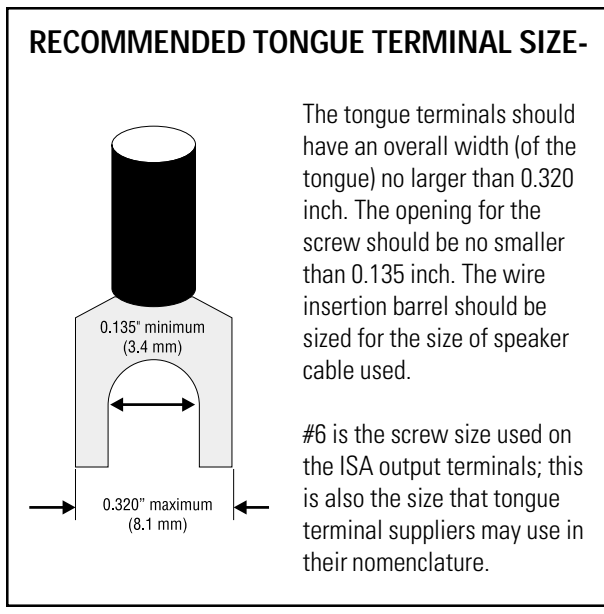
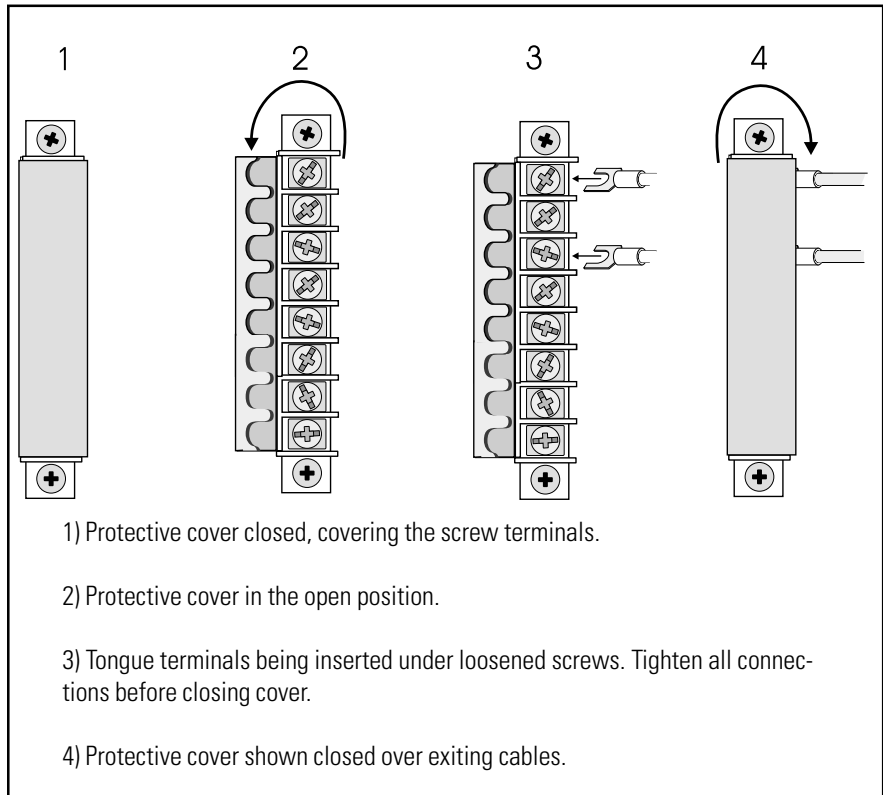

## CONNECTIONS: OUTPUTS- DIRECT LOW IMPEDANCE (LO-Z)

ISA amplifiers are equipped with screw-terminal output connections. The ISA 280, ISA 450 and ISA 750 provide low-impedance outputs only (2 to 16 ohms) while the ISA 300T, ISA 500T and ISA 800T provide both low-impedance and high-impedance (25V, 70V and 100V) outputs.

When selecting speaker cable (wire), always use the largest wire size and shortest length of wire practical for any given installation. Larger wire sizes and shorter lengths minimize power loss and degradation of damping factor. *Do not place speaker cables next to input wiring.*

**Direct Low Impedance Output Connections-** Use these terminals for 2 through 16 ohm loads.

**STEREO or PARALLEL Mode:** Connect each speaker cable to its respective channel's screw terminals. Make sure speaker polarity is maintained. Note that channel 1 and channel 2 connections have the positive (+) terminal in different locations.

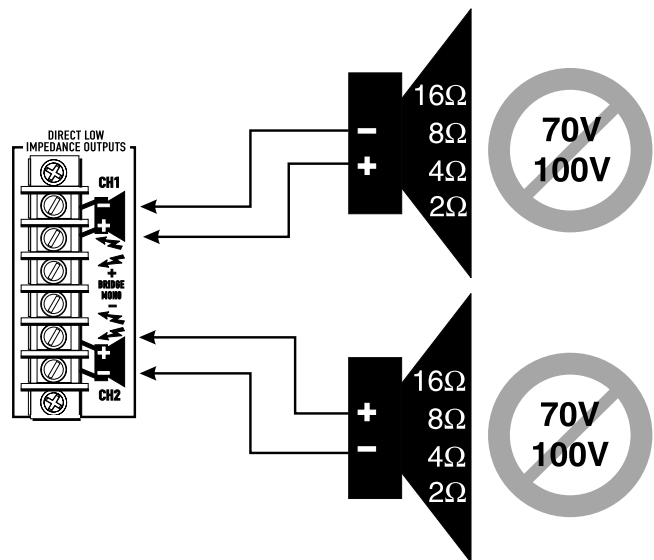

**BRIDGE Mode:** Connect the one speaker cable to the center screw terminals labeled BRIDGE MONO. Make sure speaker polarity is maintained. 2 ohm loads are not usable in BRIDGE mode.

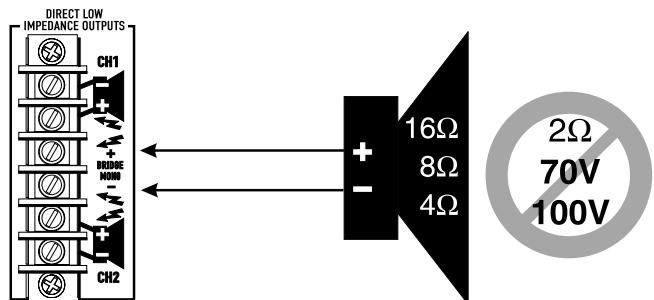

### BRIDGE MODE PRECAUTIONS:



**Do Not Use 2 ohm Loads in Bridge Mono Mode! 4 ohms is the minimum impedance for bridge mono operation!**

**This mode puts a high demand on the amplifier and speaker. Excessive clipping may cause protective muting or speaker damage. Ensure the speaker has a sufficient power rating.**



**Output voltages greater than 100 volts rms are available between the amplifier's bridged terminals. CLASS 2 or CLASS 1 wiring methods, as specified in accordance with national (NEC) and local codes, must be used to connect the speaker. To prevent electric shock, do not operate the amplifier with any conductors of the speaker cable exposed. Consult the local & national electrical codes for full information.**



# CONN

70

connected from  
negat

100V outputs are provided for bridge mono  
not be made bridged

BRIDC  
100 volt

maintain

betwe

Cc

## 200 volt line:

Connect the 200 volt line between the CH1 100 terminal and the CH2 100 terminal.

Note that the positive (+) terminal is connected to channel 1's 100 volt terminal and the negative terminal

is connected to channel 2's 100 volt terminal.

Ensure proper polarity is maintained in all connections.

Note polarity of connections when the two drivers in series.

### SAFETY WARNING

Do not touch terminals while amplifier is powered.  
High voltage energy!

Class 2 wiring may be used. For bridged mono and 100V distributed outputs class

200V D  
Connect  
Connect





## CTIONS: SE

ity sound system in  
the screw termina  
s are prevented fr

rs have integral  
able. Securing  
ese tie-down m

tions have be  
p. Working f  
een secure

s  
until



# OPERATION: AC POWER SWITCH, LED INDICATORS, GAIN CONTROLS

## AC POWER SWITCH

Before applying power, check all connections and turn down the gain controls. When the AC power is switched on, the power indicator LED will light at half brightness and the fan will start. The outputs are muted. Then the power indicator fully illuminates and the amplifier unmutes. The clip and signal LEDs will flash briefly. When the clip LEDs go out, the amplifier is ready.

After the amplifier has been powered up, slowly increase the Gain settings for each channel and check for the proper operation of all speaker loads. If you detect any problems with speakers or wiring, turn the amplifier off, correct the problem and try again. Once the system has been tested, adjust Gain levels as required.

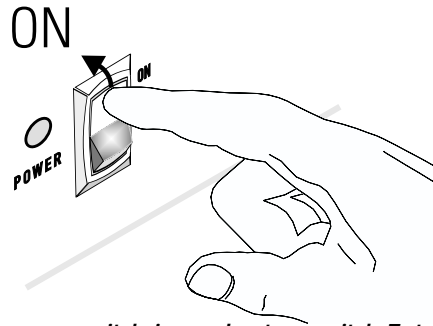

*The power switch is a rocker-type switch. To turn the amplifier on, push in on the top portion of the switch. To turn the amplifier off, push in on the bottom portion of the switch. The green power LED should illuminate when the switch is in the on position. The LED may take several seconds to extinguish when the power is switched off, this is normal.*

## GAIN CONTROLS

The Gain controls are located on the rear panel of the amplifier as shown on page 6. The controls are detented (11 steps) for repeatable adjustment. Surrounding the Gain control, the power attenuation level is shown in dB. To operate the Gain control, rotate the control's knob so that the desired level is achieved. There is a detent in the knob to indicate its position.

## NORMAL OPERATING LEVELS

The amplifier's protective muting system guards against excessive internal temperatures. With normal ventilation and 4 to 8 ohm loads, the amplifier will handle any signal level, including overdrive. Lower load impedances and higher signal levels produce more internal heating. When using 2 ohm loads, frequent or prolonged clipping may trigger thermal shutdown.

**A NOTE ON SOUND PRESSURE LEVELS-** Sound is heard as the ear converts vibration from sound waves into impulses in the nerves of the ear. Sounds above 90 decibels, particularly if the sound is prolonged, may cause such intense vibration that the inner ear is damaged. 90 decibels is about the loudness of a large truck about 5 yards away. A jackhammer emits sounds of about 120 dB from 3 feet away, and a jet engine emits sound of about 130 dB from 100 feet away. Motorcycles, snowmobiles, and similar engines range around 85 to 90 dB, and a rock concert may approach 100 dB. A general rule of thumb is that if you need to shout to be heard, the sound is in the range that can damage hearing.

Some jobs in the entertainment industry involving loud noise from music carry high risk for hearing loss. In the U.S., the maximum job noise exposure is regulated by law. Both the length of exposure and the extent (decibel level) of exposure are considered. ***If exposure is at or greater than the maximum exposure, protective measures must be taken.*** The table at right is referenced from OSHA's Permissible Noise Exposure table G16.

## FRONT PANEL LED INDICATORS

At full brightness, the green power LED indicates that the amplifier is operating. Half brightness indicates the amp is in its muting mode.

As the input signal strength increases, the green signal LED indicators will illuminate.

The red clip LED indicator flashes during overload (clipping). A bright, steady glow indicates protective muting; if this occurs during use, see Troubleshooting.

***NOTE! Page 7 contains detailed descriptions of the LED's and how to interpret their indications.***

| Duration of Exposure (per day) in Hours | Sound Level (dBA, slow response) |
|---|----------------------------------|
| 8                                       | 90                               |
| 6                                       | 92                               |
| 4                                       | 95                               |
| 3                                       | 97                               |
| 2                                       | 100                              |
| 1.5                                     | 102                              |
| 1                                       | 105                              |
| 0.5                                     | 110                              |
| 0.25                                    | 115                              |

# APPLICATIONS: GENERAL APPLICATION INFORMATION

## General ISA Application Information-

The ISA 280, ISA 450 and ISA 750 amplifiers are optimized for directly driving low impedance loads. Low impedance (Lo-Z) loads are those loads between 2 and 16 ohms. These models are not suitable for driving "constant voltage" 70V lines. These low impedance models are referred to collectively as the "non-T" models. The Lo-Z outputs will handle impedances down to 2 ohms. 2 ohm loads demand substantially higher output currents from the amplifier and should be approached with some caution. If operated at reasonable power levels (similar to 1/8 rated power with pink noise test signal) with 2 ohm loads, the amplifier will perform exceptionally. At high power with chest-pounding bass program material, excessive clipping with 2 ohm loads may cause excessive heat in the amplifier and trigger thermal shutdown.

The ISA 300T, ISA 500T and ISA 800T amplifiers have the additional capability of driving constant voltage distributed audio lines of 25, 70 and 100 volts. The outputs are autotransformer coupled; they are not fully isolated. These autotransformer equipped models also have low impedance outputs for added flexibility of system design and configuration. The total available output power from each channel can be shared between the direct low impedance outputs and the autotransformer coupled high impedance outputs. These high impedance capability models are referred to collectively as the "T" models.

## Distributed Line Principles ("T" models only)

Distributed lines are the easiest and most reliable way of distributing audio to many low-power speaker loads located over a wide area. It is easy to use because all the loads are connected in parallel across a pair of wires; there is normally no need to put speakers in series or series-parallel arrangements to meet specific impedance requirements. It is reliable because the parallel connection scheme makes it so that if any one speaker fails, the remaining speakers will continue to operate. Additionally, since the operating voltage of distributed lines is fairly high, the current through the line is kept fairly small; this minimizes resistive losses in the wiring.

Distributed line systems are usually referred to by their nominal operating voltage with 25, 70 and 100 volt systems being the most common. The main difference with the various operating voltages will be the "type" of matching transformer on the speaker assembly. In the illustration below, the 70 volt transformer is connected to the 70 volt output terminals of channel 2 of the amplifier. The input to the transformer may be connected to different "taps" that determine the nominal power that will be delivered to the speaker. The example shows taps available for 2.5, 5, 10 and 20 watts with 10 watts selected. Some transformers have the capability of matching the distributed line to several speaker impedances. If this is the case in your system, ensure that the speaker is connected to the tap that matches its impedance. 70 volt systems are common in North America, while 100 volt systems are more common in Europe. 25 volt systems are typically older commercial intercom-type components being maintained with new amplifiers.

The example below shows a 70 volt line with one speaker load attached. Most distributed lines will have many speakers connected in parallel across the line. To estimate the power handling requirements for a line, simply add up all the "speaker load powers". Below, the selected "speaker load power" is 10 watts. If there were 10 of these exact same loads on the line, then the line would represent a 100 watt load to the amplifier's 70 volt output terminals. The example would be the same if the system were 25 volt or 100 volt. Only the matching transformer would be marked with the 25V or 100V rating and the connections to the amplifier would be at the appropriate 25V or 100V output terminals.

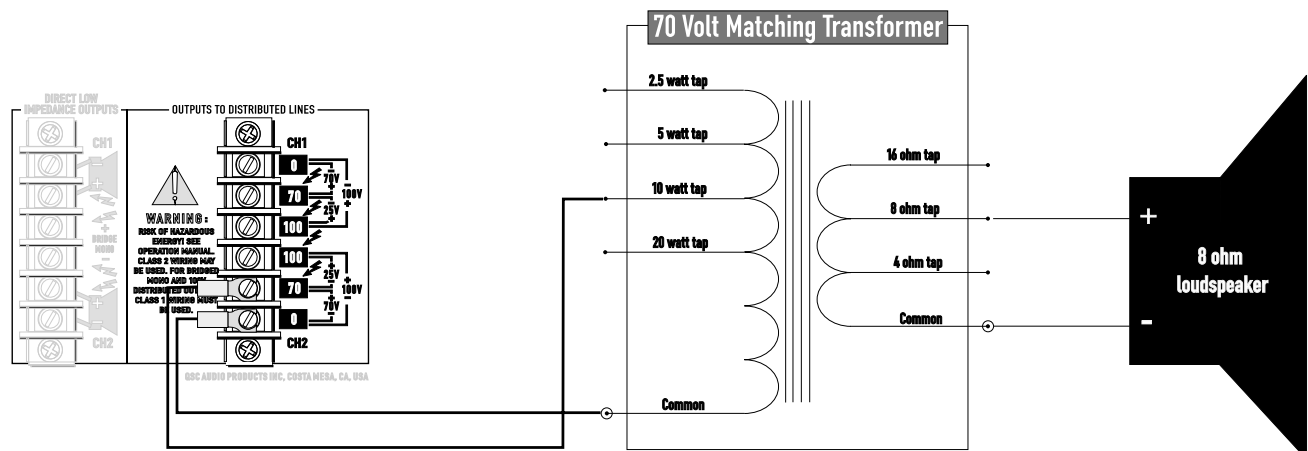

# APPLICATIONS: LOW FREQUENCY FILTERING & DISTRIBUTED OUTPUTS

## Low Frequency Filtering for 70-100V Systems-

The low frequency filtering is another difference in the characteristics of the “non-T” and the “T” amplifiers. Because transformers and other magnetic devices are prone to low frequency “misbehavior” (called saturation), the autotransformer equipped “T” models are low frequency limited. The default low frequency roll-off is at 50 hertz; 75 hertz is the other available selection. **Low frequency filtering is always active on the “T” models.** This low frequency roll-off is required primarily to protect the smaller matching transformers on the speakers of constant voltage distributed audio systems, but also aids in minimizing low frequency distortion of the system in general.

The varying degree of quality of coupling transformers may require the roll-off frequency to be set to the higher 75 hertz selection. The change from 50 to 75 hertz may seem minor, but in terms of low frequency drive, it reduces the required “magnetic flux” of the coupling transformers by about 30%. If the application requires driving speaker loads at or near their rated power, or with program material that’s heavy on the bass, a marked performance increase may be realized with the 75 hertz low frequency roll-off. A careful system listening evaluation will aid in the best selection for any application.

The low frequency filter is not a “brick wall” and if the input level is increased beyond 100% it is possible to “over-ride” the filter to some extent. Normally, such signal levels will cause the amplifier to clip, which is the first sign of potential danger. Midband clipping puts no unusual strain on the transformers, but full-range material with heavy clipping will probably overdrive the 70-100V transformers to saturation, even with the 50 Hz filter. This will cause an additional layer of “hash” in the clipping, and will also result in audible clicking noises from the transformers inside the amplifier. These symptoms indicate abnormal stress and should be avoided for maximum service life. If unpredictable clipping is possible, use the Clip Limiter to prevent long-term overloads and use the 75 Hz filter position for extra protection. The clip limiter will not effect performance where no clipping is present, and therefore is recommended as the default setting. The 50 Hz filter is suitable for program material which remains within the amplifier’s normal headroom and will provide slightly better bass on wide-band speakers.

If a system with sub-woofers is desired, we recommend the use of the low-impedance ISA 280, ISA 450 or ISA 750 with low-impedance sub-woofer drivers. The low frequency performance of the directly-coupled system is superior to the magnetically-coupled systems. Remember that all of the outputs on the “T” models are low frequency limited to 50 hertz by default. For all applications requiring audio performance below 50 hertz, use the low impedance, “non-T” models with low impedance speakers.

## Distributed Output Application Examples-

### 25 Volt, two-zone example:

The illustration to the right shows a typical two-zone 25 volt system. When using 25 volt speaker loads, make sure that connections to the amplifier are made to the 25 volt output terminals.

If using the ISA 300T, 300 watts per channel (zone) can be delivered. Make sure that the total speaker power load on each channel does not exceed 300 watts.

If using the ISA 500T or ISA 800T, the per-channel power limit is 550 and 800 watts, respectively.

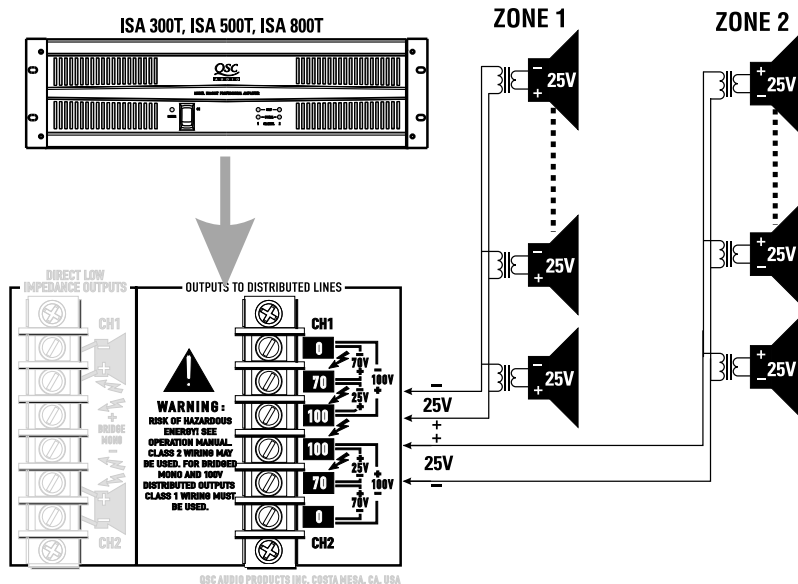

### OUTPUT TERMINAL SAFETY WARNING!

Do not touch output terminals while amplifier power is on. Make all connections with amplifier turned off. Risk of hazardous energy!



Class 2 wiring may be used. For bridged mono and 100V distributed outputs, class 1 wiring must be used.

# APPLICATIONS: DISTRIBUTED OUTPUTS

## 70 Volt, two-zone example:

The illustration to the right shows a typical two-zone 70 volt system. When using 70 volt speaker loads, make sure that connections to the amplifier are made to the 70 volt output terminals.

If using the ISA 300T, 300 watts per channel (zone) can be delivered. Make sure that the total speaker power load on each channel does not exceed 300 watts.

If using the ISA 500T or ISA 800T, the per-channel power limit is 550 and 800 watts, respectively.

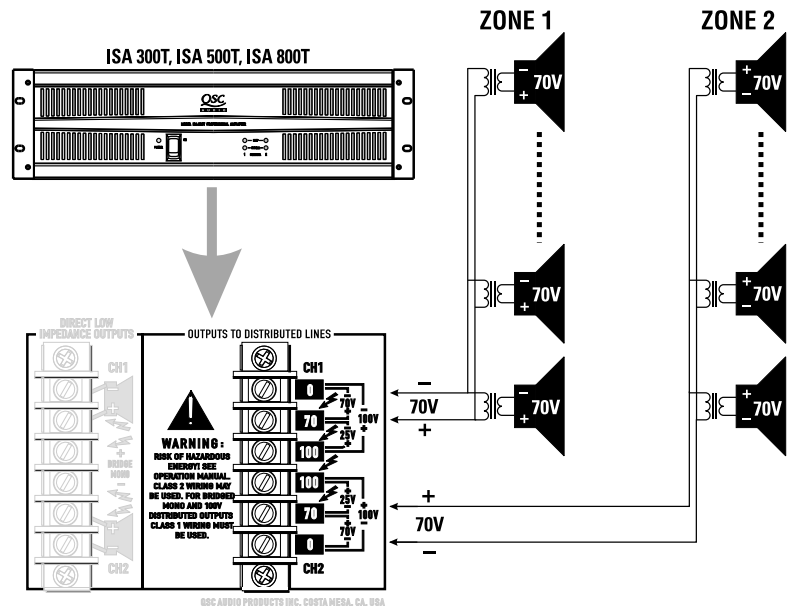

## 100 Volt, two-zone example:

The illustration to the right shows a typical two-zone 100 volt system. When using 100 volt speaker loads, make sure that connections to the amplifier are made to the 100 volt output terminals.

If using the ISA 300T, 300 watts per channel (zone) can be delivered. Make sure that the total speaker power load on each channel does not exceed 300 watts.

If using the ISA 500T or ISA 800T, the per-channel power limit is 550 and 800 watts, respectively.

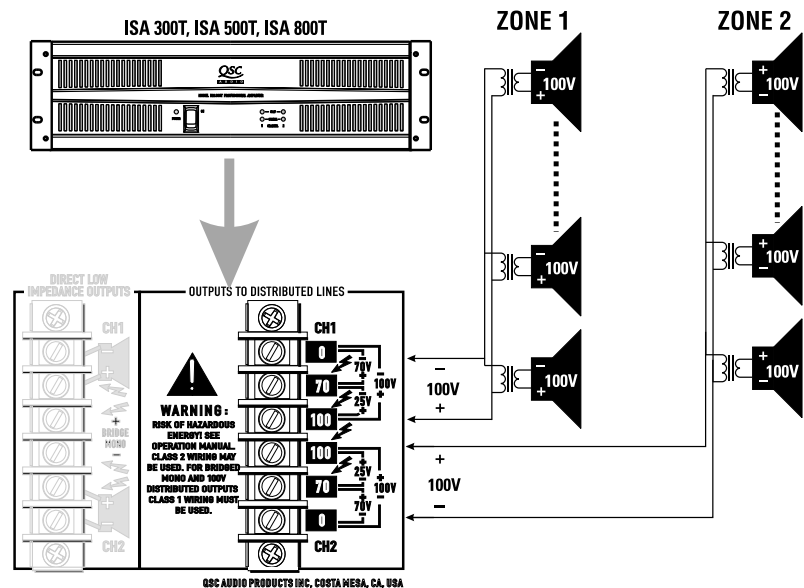

## Bridge Mode Using Hi-Z Outputs-

Bridging of the Hi-Z outputs is possible with the "T" models; see page number 22.



### OUTPUT TERMINAL SAFETY WARNING!

Do not touch output terminals while amplifier power is on. Make all connections with amplifier turned off. Risk of hazardous energy!



Class 2 wiring may be used. For bridged mono and 100V distributed outputs, class 1 wiring must be used.

PLICATION

variation  
of impedance  
at connection points"

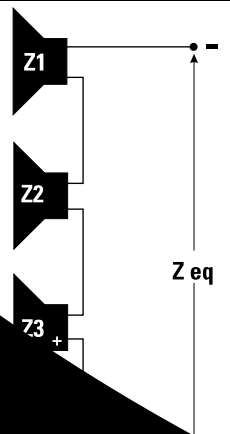
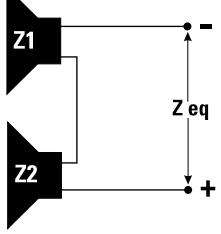

π  
π

phasor



## APPLICATIONS: DataPort V2 (all models)

---

Below are listed the available QSC DataPort-compatible products that will interface with your ISA amplifier. This list will continuously change as new products become available and old products are discontinued. Always use a QSC DataPort cable for remote equipment interconnect. Computer data cables, although similar in appearance, will not function properly and may damage your equipment. Contact your QSC dealer for details and for QSC accessories. This listing is current at time of writing, for up-to-date accessory information, contact your QSC representative.

**The DSP-3 Digital Signal Processing Module** provides compressor-limiter, multiple parametric filters, high- and low-pass filters, shelf filters, multiple delays, polarity reversal, muting and attenuation. These features and more come packed into a small module that interfaces with the DataPort V2 connector on the rear of your ISA amplifier. Not all features of the DSP-3 are available via the "Version 2" DataPort; consult your QSC sales professional for full details. The accessory remote power supply must be used to supply DC power to the DSP-3; accessory module power is NOT provided by the ISA amplifiers.

**The XC-3 Crossover** provides a built-in active two-way crossover. It features fourth-order Linkwitz-Riley filters with SIP selectable crossover frequencies, DIP-switch control of high-frequency equalization for CD horn equalization, SIP selectable subsonic filter, and SIP selectable all-pass low-frequency delay.

**The SF-3 Subwoofer Filter** is used primarily as an adjustable bandpass filter for subwoofers. The filter may be configured for a flat roll-off or a boosted response to equalize certain subwoofer models with step-down tuning. The use of a subsonic filter at the vented box tuning frequency protects speakers from damage and prevents the waste of amplifier power on excessive and inaudible low-frequency noise.

**The LF-3 Low Frequency Filter** is a new module for tri-amp applications. The LF-3 provides low-frequency bandpass filters for each amp channel and is used in conjunction with XC-3's to power a tri-amp system. The XC-3 provides mid and high-pass functions for each speaker system.

**The DCM Crossover & Monitors** will work with the ISA amplifiers. The "AMP TYPE" selection in software MUST be set to UNKNOWN. This will disable the load fault detection and AC power control as these features are not supported by the ISA series. Consult your QSC applications engineer regarding integration of ISA amplifiers with DCM products.

**The CM16a Amplifier Network Monitor** will not work with the ISA series of amplifiers.



*Always use a QSC DataPort cable for remote equipment interconnect. Computer data cables, although similar in appearance, will not function properly and may damage your equipment.*



# TROUBLESHOOTING: NO SOUND

---

## **Problem: NO SOUND**

### • **INDICATION: POWER LED INDICATOR NOT ILLUMINATED**

- Check both ends of the AC line cord for proper connection. Both ends should be fully seated in their connectors.
- Check that the AC outlet works by plugging in a known-good device or by testing with a voltmeter. If too many amplifiers are used on one outlet, the building's circuit breaker may trip and shut off power. If this is the case, unplug some of the amplifiers from the outlet, reset the building's breaker and try again. For the other amps, use an outlet that is connected to another circuit breaker to distribute the load current.
- Check the rear panel circuit breaker on the amplifier. It should not have its white colored "trip" indicator showing. If it does, reset the breaker by pushing the indicator back in until it clicks and locks inward.
- An amplifier which keeps tripping its circuit breaker may have a serious internal fault. Turn it off, remove AC power, and have the amplifier serviced by a qualified technician.

### • **INDICATION: SIGNAL LED'S NOT RESPONDING TO INPUT SIGNAL LEVEL (NOT LIGHTING)**

- If the green power indicator LED is lit, but the signal LEDs do not light up at all, check the input. Make sure the signal source is working and try another input cable. Connect the source to another channel or amplifier to check that it is working.
- If you are using the XLR or terminal block inputs, be sure the connectors are fully inserted at both ends of all interconnecting cables. If you are using the DataPort for your input signal, ensure the DataPort cable is properly connected at both ends and that the device supplying the audio signal to the DataPort is properly configured.

### • **INDICATION: SIGNAL LEDS RESPONDING TO SIGNAL LEVEL**

- If the green signal LED indicators are lighting normally, the fault is somewhere between the amp and the speakers. Check the speaker wiring for breaks. Check for proper connection at each end. Try another speaker and cable, if necessary. If your system has multiple speakers connected in series, any one speaker failure will cause all other speakers (in the same series circuit) to lose their signal.

### • **INDICATION: CLIP LED FLASHING**

- If the red clip indicator flashes when signal is applied, the amplifier output may be shorted. Check that the speaker cable connections are tight and reliable at both ends. Check the speaker cables for stray strands or breaks in the insulation. Trim off all loose strands of wire and insulate any exposed wire with electrical tape. All connections should be made with great care and all wire terminations should be carefully checked to ensure quality workmanship.
- If the red clip indicator flashes when connecting the speaker cable between the + and - terminals, then that speaker cable (or speaker) may be shorted. Check the cable and the speaker.

### • **INDICATION: CLIP LEDS BRIGHT AND STEADY**

*The amplifier is in protective muting.*

- Three seconds or so of muting is normal when the amp is turned on. After power-up muting, the clip LED should go out.
- Overheating will cause protective muting and the clip LED to fully illuminate. If the amp is overheated, the fan will be running at full speed and the chassis will be very warm to the touch; sound should resume within a minute as the amplifier cools to a safe operating temperature. **DO NOT TURN THE AMP OFF!** This would stop the fan from cooling the inside of the amplifier. Instead, reduce the input signal ( or amp gain setting) and wait for the amp to resume operation automatically.
- Check for proper ventilation. If the fan isn't running at all, the amplifier requires servicing.

## **TROUBLESHOOTING: DISTORTION, NO CHANNEL SEPARATION, HUM, HISS, FEEDBACK**

---

**PROBLEM: DISTORTED SOUND**

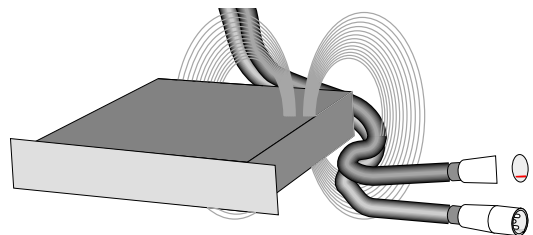

*Magnetic field from power supplies in equipment can induce hum into cabling that is located in the field. If hum is a problem, try relocating cabling so that is away from power supplies, transformers and other magnetic field producing devices.*

| SPECIFICATIONS  | ISA 280   | ISA 450               | ISA 750               |
|---|---|-----------------------|-----------------------|
| <b>OUTPUT POWER <i>in watts</i></b>   |   |                       |                       |
| <i>FTC:</i> 8 ohms per channel (20-20k Hz., 0.1% THD)                         | 185   | 260                   | 450                   |
| 4 ohms per channel (20-20k Hz., 0.1% THD)                                     | 280   | 425                   | 650                   |
| <i>EIA:</i> 16 ohms (1 kHz., 0.1% THD, 1 channel driven)                      | 100   | 140                   | 250                   |
| 8 ohms (1 kHz, 0.1% THD, 1 channel driven)                                    | 200   | 280                   | 475                   |
| 4 ohms (1 kHz, 0.1% THD, 1 channel driven)                                    | 300   | 500                   | 750                   |
| 2 ohms (1 kHz, 1% THD, both channels driven)                                  | 430   | 700                   | 1200                  |
| <i>Bridged Mono:</i>  |   |                       |                       |
| 16 ohms, 20-20k Hz, 0.1% THD  | 370   | 520                   | 900                   |
| 8 ohms (1 kHz, 0.1% THD)  | 600   | 900                   | 1500                  |
| 4 ohms (1 kHz, 1% THD)  | 830   | 1400                  | 2400                  |
| <b>DYNAMIC HEADROOM</b> (all models)  | 2 dB at 4 ohms  |                       |                       |
| <b>DISTORTION</b> (SMPTE-IM, all models)                                      | LESS THAN 0.01%   | LESS THAN 0.01%       | LESS THAN 0.01%       |
| <b>FREQUENCY RESPONSE</b> (all models)<br>(at 10 dB below rated output power) | 20 Hz to 20 kHz, +0, -1 dB<br>-3 dB points: 5 Hz and 50 kHz |                       |                       |
| <b>DAMPING FACTOR</b> (all models)  | Greater than >200 for 8 ohm load                            |                       |                       |
| <b>SIGNAL to NOISE</b> (unweighted, 20-20k Hz.)                               | -100 dB   | -100 dB               | -100 dB               |
| <b>VOLTAGE GAIN</b> (gain control set to 0 dB)                                | 30.5 dB (33.4 X)  | 33.0 dB (44.7 X)      | 35.0 dB (56.2 X)      |
| <b>INPUT SENSITIVITY</b> for rated power into 8 ohms                          | +3.43 dBu (1.15 Vrms)                                       | +2.81 dBu (1.07 Vrms) | +2.81 dBu (1.07 Vrms) |
| <b>INPUT CLIPPING, Vrms</b> (all models)                                      | +22 dBu   |                       |                       |
| <b>INPUT IMPEDANCE</b> (all models)   | 10k ohms unbalanced , 20k ohms balanced                     |                       |                       |

# SPECIFICATIONS

## ISA 280

## ISA 450

## ISA 750

|  |  |   |   |
|--|--|---|---|
| <b>AMPLIFIER PROTECTION</b>  | Full short circuit, open circuit, thermal, ultrasonic and RF protection.<br>Stable into reactive or mismatched loads.  |   |   |
| <b>COOLING</b>   | Continuously variable speed fan; back-to-front air flow.   |   |   |
| <b>INDICATORS</b>  | Front Panel: POWER LED (green), 2 each SIGNAL (green) and CLIP (red) LEDs  |   |   |
| <b>CONNECTORS</b>  | Input: (2)XLR, (2)terminal block ("euro" or "Phoenix") and (1)QSC DataPort V2 connector<br>Output: screw-terminal barrier strip direct low impedance outputs   |   |   |
| <b>LOAD PROTECTION</b>   | Turn-on/turn-off muting<br>AC coupling<br>Clip limiting  | Turn-on/turn-off muting<br>AC coupling<br>Clip limiting | Turn-on/turn-off muting<br>Clip limiting<br>Triac Crowbar |
| <b>OUTPUT CIRCUIT TYPE</b>   | AB   | AB  | Class-H   |
| <b>POWER REQUIREMENTS</b>  | SEE SERIAL NUMBER LABEL ON REAR PANEL FOR THE SPECIFIED OPERATING VOLTAGE  |   |   |
| <b>POWER CONSUMPTION @ 120 VAC, typical (both channels driven)</b>   |  |   |   |
| Idle   | 0.3  | 0.4   | 0.5   |
| 1/8 power, 8 ohms*   | 2.6  | 3.5   | 4.5   |
| 1/8 power, 4 ohms*   | 4.1  | 5.9   | 7.0   |
| 1/8 power, 2 ohms*   | 6.2  | 9.1   | 10.3  |
| <i>NOTE: 1/8 power is representative of current draw with typical music program material with occasional clipping. *Pink noise</i> |  |   |   |
| <b>CONTROLS</b> (all models)   | <b>Front:</b> AC POWER switch<br><br><b>Back:</b> Gain controls, DIP switch block with 10 poles: Clip Limiters, Stereo/Parallel/Bridge mode selection, low frequency filter on-off and frequency selection |   |   |
| <b>DIMENSIONS</b> (all models)   | 19.00" (48.3 cm) wide, 5.20" (13.2 cm) tall (3 rack spaces)<br>15.75" (40.0 cm) deep (from front mounting rails) including rear support ears   |   |   |
| <b>WEIGHT</b>  | 36 pounds (16.3 kg.)   | 36 pounds (16.3 kg.)                                    | 47 pounds (21.3 kg.)                                      |

**SPECIFICATIONS SUBJECT TO CHANGE WITHOUT NOTICE**

| SPECIFICATIONS  | ISA 300T  | ISA 500T              | ISA 800T              |
|---|---|-----------------------|-----------------------|
| <b>OUTPUT POWER <i>in watts</i></b>   |   |                       |                       |
| <i>Low Impedance FTC:</i>   |   |                       |                       |
| 8 ohms per channel (20-20k Hz., 0.1% THD)   | 185   | 260                   | 450                   |
| 4 ohms per channel (20-20k Hz., 0.1% THD)   | 280   | 425                   | 650                   |
| <i>Low Impedance EIA:</i>   |   |                       |                       |
| 16 ohms (1 kHz., 0.1% THD, 1 channel driven)                                      | 100   | 140                   | 250                   |
| 8 ohms (1 kHz, 0.1% THD, 1 channel driven)  | 200   | 280                   | 475                   |
| 4 ohms (1 kHz, 0.1% THD, 1 channel driven)  | 300   | 500                   | 750                   |
| 2 ohms (1 kHz, 1% THD, both channels driven)                                      | 430   | 700                   | 1200                  |
| <i>Low Impedance Bridged Mono:</i>  |   |                       |                       |
| 16 ohms, 20–20k Hz, 0.1% THD  | 370   | 520                   | 900                   |
| 8 ohms (1 kHz, 0.1% THD)  | 600   | 900                   | 1500                  |
| 4 ohms (1 kHz, 1% THD)  | 830   | 1400                  | 2400                  |
| <i>Distributed High Impedance:</i>  |   |                       |                       |
| 70 volt (50 Hz - 16 kHz, 0.5% THD, per channel)                                   | 300   | 500                   | 800                   |
| 100 volt  | 300   | 500                   | 800                   |
| 140 volt (bridge)   | 600   | 1000                  | 1600                  |
| 200 volt (bridge)   | 600   | 1000                  | 1600                  |
| <b>DYNAMIC HEADROOM</b> (all models)  | 2 dB at 4 ohms  |                       |                       |
| <b>DISTORTION</b> (SMPTE-IM, all models)  | LESS THAN 0.01%   | LESS THAN 0.01%       | LESS THAN 0.01%       |
| <b>FREQUENCY RESPONSE</b> (all "T" models)<br>(at 10 dB below rated output power) | <b>DIRECT OUTPUTS-</b> -3 dB at 50 Hz to -0.5 dB at 20 kHz<br><b>DISTRIBUTED OUTPUTS-</b> 50 Hz to 16 kHz, +0 dB, -3 dB |                       |                       |
| <b>DAMPING FACTOR</b> (all models)  | Greater than >200 for 8 ohm load  |                       |                       |
| <b>SIGNAL to NOISE</b> (unweighted, 20-20k Hz.)                                   | -100 dB   | -100 dB               | -100 dB               |
| <b>VOLTAGE GAIN</b> (gain control set to 0 dB)                                    | 30.5 dB (33.4.X)  | 33.0 dB (44.7 X)      | 35.0 dB (56.2 X)      |
| <b>INPUT SENSITIVITY</b> for rated power into 8 ohms                              | +3.43 dBu (1.15 Vrms)   | +2.81 dBu (1.07 Vrms) | +2.81 dBu (1.07 Vrms) |
| <b>INPUT CLIPPING, Vrms</b> (all models)  | +22 dBu   |                       |                       |
| <b>INPUT IMPEDANCE</b> (all models)   | 10k ohms unbalanced , 20k ohms balanced   |                       |                       |

## SPECIFICATIONS

## ISA 300T

## ISA 500T

## ISA 800T

### AMPLIFIER PROTECTION

Full short circuit, open circuit, thermal, ultrasonic and RF protection.  
Stable into reactive or mismatched loads.

### COOLING

Continuously variable speed fan; back-to-front air flow.

### INDICATORS

Front Panel: POWER LED (green), 2 each SIGNAL (green) and CLIP (red) LEDs

### CONNECTORS

Input: (2)XLR, (2)terminal block ("euro" or "Phoenix") and (1)QSC DataPort V2 connector  
Output: screw-terminal barrier strip

### LOAD PROTECTION

|                         |                         |                         |
|-------------------------|-------------------------|-------------------------|
| Turn-on/turn-off muting | Turn-on/turn-off muting | Turn-on/turn-off muting |
| AC coupling             | AC coupling             | Triac crowbar           |
| Clip limiting           | Clip limiting           | Clip Limiting           |

### OUTPUT CIRCUIT TYPE

|    |    |         |
|----|----|---------|
| AB | AB | Class-H |
|----|----|---------|

### POWER REQUIREMENTS (all models)

SEE SERIAL NUMBER LABEL ON REAR PANEL FOR THE SPECIFIED OPERATING VOLTAGE

### CURRENT CONSUMPTION @ 120 VAC, typical (both channels driven) in Amperes

|                         |     |     |      |
|-------------------------|-----|-----|------|
| Idle                    | 0.3 | 0.4 | 0.5  |
| 1/8 power, 8 ohms*      | 2.6 | 3.5 | 4.5  |
| 1/8 power, 4 ohms*      | 4.1 | 5.9 | 7.0  |
| 1/8 power, 2 ohms*      | 6.2 | 9.1 | 10.3 |
| 1/8 power, 70V or 100V* | 5.5 | 6.9 | 8.5  |

*NOTE: 1/8 power is representative of current draw with typical music program material with occasional clipping. \*Pink noise*

### CONTROLS (all models)

**Front:** AC POWER switch

**Back:** Gain controls, DIP switch block with 10 poles: Clip Limiters, Stereo/Parallel/Bridge mode selection, low frequency filter frequency selection.

### DIMENSIONS (all models)

19.0" (48.3 cm) wide, 5.2" (13.2 cm) tall (3 rack spaces)  
15.75" (40.0 cm) deep (from front mounting rails) including rear support ears

### WEIGHT (all models kg.)

|                      |                      |                 |
|----------------------|----------------------|-----------------|
| 44 pounds ( 20.0 kg) | 44 pounds ( 20.0 kg) | 55 pounds (25.0 |
|----------------------|----------------------|-----------------|

**SPECIFICATIONS SUBJECT TO CHANGE WITHOUT NOTICE**

# WARRANTY INFORMATION & HOW TO CONTACT QSC

**WARRANTY** *(USA only; other countries, see your dealer or distributor)*



## Disclaimer

QSC Audio Products, Inc. is not liable for any damage to speakers, amplifiers, or any other equipment that is caused by negligence or improper installation and/or use of the ISA amplifier.

## Product Warranty

QSC guarantees the ISA amplifier to be free from defective material and/or workmanship for a period of three years from the date of sale, and will replace defective parts and repair malfunctioning products under this warranty when the defect occurs under normal installation and use—provided the unit is returned to our factory via prepaid transportation with a copy of the proof of purchase, i.e., sales receipt. This warranty provides that examination of the returned product must indicate, in our judgment, a manufacturing defect. This warranty does not extend to any product which has been subjected to misuse, neglect, accident, improper installation, or where the date code has been removed or defaced.

## HOW TO CONTACT QSC AUDIO PRODUCTS



**Mailing address / Adresse postale / Postanschrift / Dirección postal:**

QSC Audio Products, Inc.  
1675 MacArthur Boulevard  
Costa Mesa, CA 92626-1468 USA



**Telephone Numbers / Numéros de téléphone / Telefonnummern / Números de teléfono:**

Main Number / Numéro principal / Hauptnummer / Número principal

+(714) 754-6175

Sales Direct Line / Ligne directe ventes / Verkauf-Direkt / Línea directo ventas

+(714) 957-7100

Sales & Marketing / Ventes & marketing / Verkauf u. Marketing / Ventas y marketing

(800) 854-4079

*(toll-free in U.S.A. only)  
(sans frais aux É-U seulement)  
(zollfrei nur beim USA)  
(sin costo en EE. UU. solamente)*

Customer Service / Service à la clientèle / Kundendienst / Servicio a la clientela

+(714) 957-7150

(800) 772-2834

*(toll-free in U.S.A. only)  
(sans frais aux É-U seulement)  
(zollfrei nur beim USA)  
(sin costo en EE. UU. solamente)*

**Facsimile Numbers / Numéros de télécopieur / Telefaxnummern / Número de FAX:**

Sales & Marketing FAX / Télécopie ventes & marketing / Telefax der Verkauf u. Marketing / FAX ventas y marketing

+(714) 754-6174

Customer Service FAX / Télécopie service à la clientèle / Kundendienst-Telefax / FAX servicio a la clientela

+(714) 754-6173



**World Wide Web:**

[www.qscaudio.com](http://www.qscaudio.com)

**E-mail:**

[info@qscaudio.com](mailto:info@qscaudio.com)

[service@qscaudio.com](mailto:service@qscaudio.com)



**QSC Audio Products, Inc.** 1675 MacArthur Boulevard Costa Mesa, California 92626 USA

"QSC" and the QSC logo are registered with the U.S. Patent and Trademark Office.

©2000 QSC Audio Products, Inc.